

Illustra Insight Intelligent Frictionless Access Camera Installation and Configuration Guide

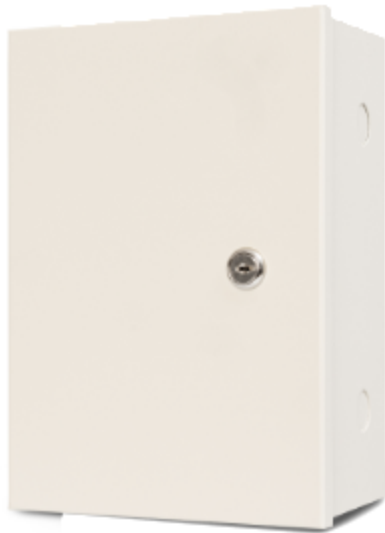

Notice

Please read this manual thoroughly and save it for future use before attempting to connect or operate this unit.

The information in this manual was current when published. The manufacturer reserves the right to revise and improve its products. All specifications are therefore subject to change without notice.

Copyright

© 2020 Johnson Controls. All rights reserved.

JOHNSON CONTROLS, TYCO and ILLUSTRATE are trademarks and/or registered trademarks. Unauthorized use is strictly prohibited.

Tyco Security Products

6600 Congress Avenue

Boca Raton, FL 33487 U.S.A.

Customer Service

Thank you for using Illustra products. We support our products through an extensive worldwide network of dealers. The dealer through whom you originally purchased this product is your point of contact if you need service or support. Our dealers are empowered to provide the very best in customer service and support. Dealers should contact American Dynamics at (800) 507-6268 or (561) 912-6259 or on the web at www.americandynamics.net.

Note:For support (within 6 months of the product launching) please contact TycoAI-support@jci.com. Troubleshooting documentation is available on the AD Support Portal - <https://support.americandynamics.net/#/product/illustra-cameras>.

Trademarks

The trademarks, logos, and service marks displayed on this document are registered in the United States [or other countries]. Any misuse of the trademarks is strictly prohibited and Tyco Security Products will aggressively enforce its intellectual property rights to the fullest extent of the law, including pursuit of criminal prosecution wherever necessary. All trademarks not owned by Tyco Security Products are the property of their respective owners, and are used with permission or allowed under applicable laws.

Product offerings and specifications are subject to change without notice. Actual products may vary from photos. Not all products include all features. Availability varies by region; contact your sales representative.

Table of Contents

Warning	5
Overview	6
Illustra Insight Intelligent Frictionless Access Camera	7
Product overview	7
Installation	7
Streaming live video	13
Access control system interface	13
Option 1: Wiegand	13
Option 2: OSDP	14
Licensing	14
Camera firmware	14
Managing cameras with the Illustra Connect tool	14
Additional Resources	15
Network Topology	16
Network Connection	18
Default IP Address	18
DHCP	19
Managing cameras with the Illustra Connect tool	20
Configuration	23
Live menu	25
Video Menu	27
Picture Settings	27
Privacy Zones	30
Frictionless Access	32
Frictionless Access	32
Security	36
Session Timeout	36
Users	37
Remote Access	39

Network Menu	40
TCP/IP	40
System	42
Maintenance	42
Date / Time	44
Audio	45
Raw Snapshot	47
Logs	47
Test	48
About	49
Appendix A: Using Media Player to View RTSP Streaming	50
Appendix B: Camera Defaults	51
Appendix C: Technical Specifications	55
Standards and Compliance	58
End User License Agreement (EULA)	60

Warning

- This unit operates at Power over Ethernet IEEE 802.3bt Type 3 Class 5.
- Installation and service should be performed only by qualified and experienced technicians and comply with all local codes and rules to maintain your warranty.
- To reduce the risk of fire or electric shock, do not expose the product to rain or moisture.
- Wipe the camera with a dry soft cloth. For tough stains, slightly apply with diluted neutral detergent and wipe with a dry soft cloth.
- Do not apply benzene or thinner to the camera, which may cause the surface of the unit to melt or lens to fog up.
- Recommended operating temperature is:
 - Satellite Camera Module: 14°F to 104°F (-10°C to 40°C).
 - Control Unit: 14°F to 104°F (-10°C to 40°C).

Overview

This Illustra Insight Facial Recognition camera Installation and Configuration Guide is a user manual which provides physical properties, installation, and configuration information of the cameras in Table 1 on Page 6.

Table 1 Product codes

Product Code	Model Name	Description
II-AN00INT01	Illustra Insight	Illustra Insight 2MP camera

The first portion of this guide contains information pertaining specifically to the aforementioned cameras.

- For the Illustra Insight 2MP camera, refer to Illustra Insight Intelligent Frictionless Access Camera on page 7.

The second portion of this guide contains information regarding the Illustra User Web Interface and the web configuration of the aforementioned cameras. Refer to Configuration on page 23 for procedural information pertaining to camera configuration.

Illustra Insight Intelligent Frictionless Access Camera

This chapter provides product features, installation procedures, and connection information regarding the Illustra Insight 2MP Facial Recognition camera.

Product overview

This chapter explains the features and installation of the Illustra Insight Facial Recognition Access Control camera. Product code and description of the camera is provided in the table below.

Table 2 Product code and description of the Illustra Insight camera

Product Code	Description
II-AN00INT01	Illustra Insight 2MP Facial Recognition Access Control camera

Installation

In the box

Check everything in the packing box matches to the order form and the packing slip. In addition to this guide, items below are included in the packing box:

- 1 x Illustra control unit
- 1 x Satellite camera module
- 1 x Quick Start Guide
- 1 x Torx bit
- 1 x Drill template
- 1 x 10m S/FTP CAT6 cable (Do **not** modify the cable)
- 2 x Cable clamp ferrites

Contact your dealer if any item is missing.

Installation Tools

- 1 x Drill

Quick Reference

- Default IP: 192.168.1.168 (DHCP enabled)
- Default Username and Password: admin / admin

Figure 3 Illustra control unit parts

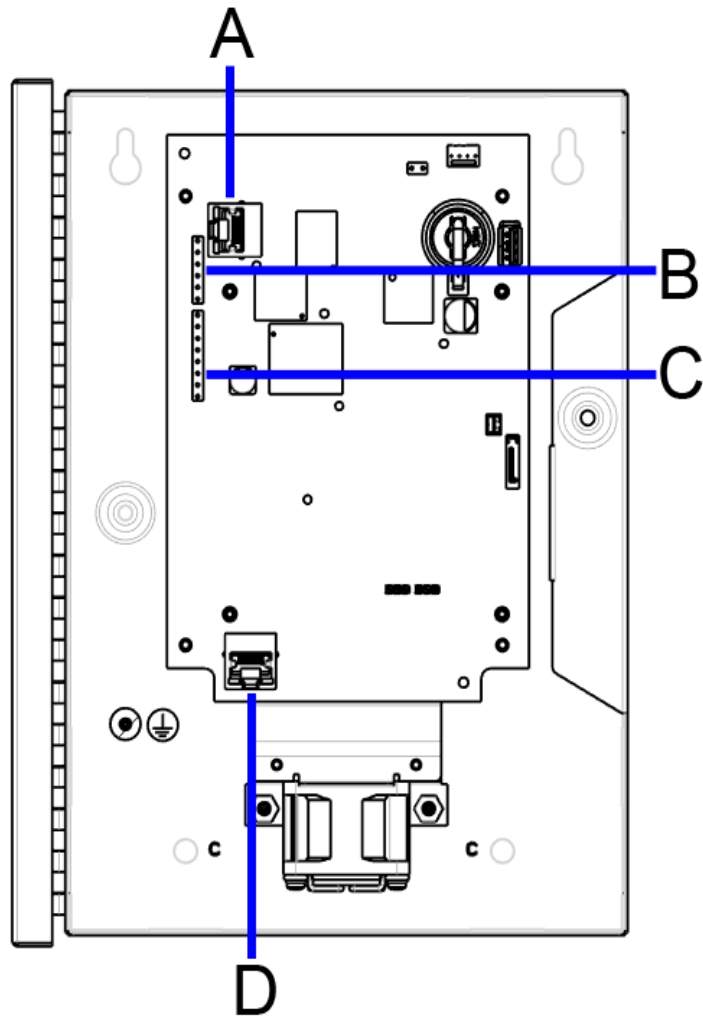

Table 4 Illustra control unit parts descriptions

Part	Description
A	Power Over Ethernet IEEE 802.3bt Network Connector (40W minimum)
B	OSDP Interface
C	Wiegand Interface
D	Satellite camera connector

Figure 5 Illustra Insight camera parts

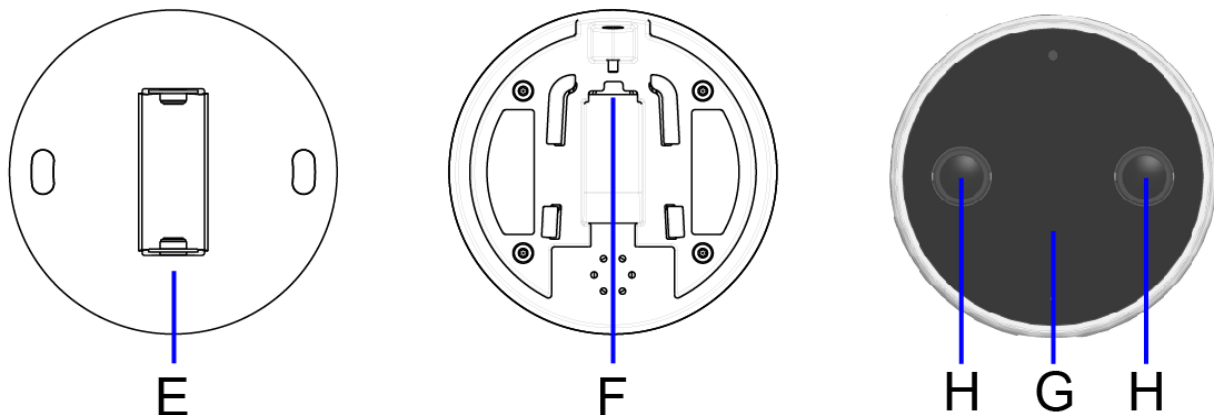

Table 6 Illustra Insight camera part descriptions

Part	Description
E	Wall Mounting Bracket
F	Location of the Satellite cable connection
G	Satellite camera module
H	Lenses

Required items not included in the box (Camera 1 to the Server)

- 1 x Single port IEEE 802.3bt Injector (e.g. PoE60U-1BT) (40W minimum).
- 1 x Ethernet cable CAT5/6 from Injector output to the Illustra Control Unit.
- 1 x Ethernet cable CAT5/6 from Injector input to Facial Recognition Server Ethernet port.

Required items not included in the box (Additional number of cameras to the Server)

- 'N' x Single port IEEE 802.3bt Injector (e.g. PoE60U-1BT) (40W minimum).
- 1 x Port Gigabit Ethernet Switch.
- 'N' x Ethernet cable CAT5/6 from Injector output to the Illustra Control Unit.
- 'N' x Ethernet cable CAT5/6 from Injector input to Network Switch.
- 1 x Ethernet cable CAT5/6 from Network Switch to Facial Recognition Server Ethernet port.

Cyber-Security

Firmware updates ensure that the security and operational performance of your camera is optimized. It is important that you update Illustra Insight to the latest firmware release before use. Visit <https://illustracameras.com> for access to firmware and support documentation.

Procedure 1 Satellite camera installation

IMPORTANT: The maximum distance between the camera module and the control unit is 10 meters and you must use the supplied CAT6 cable to ensure the best quality and performance.

Step	Action
1	To attach the satellite camera to a surface, place the mounting template on the surface at recommended height of 62" (5.2 foot / 1.6m / 1575mm) and drill holes that correspond to those identified on the template for mounting and cable tray purposes.
2	Place the mounting bracket onto the surface and align the holes on the mounting bracket with the holes on the surface and ensure that the bracket is level and the screw in place.

Note:The camera end of the CAT6 S/FTP cable in the wall should be passed through the bracket mounted on the wall and be plugged into the back of the satellite camera module (F) (Figure 2).

3	Place the camera onto the mounting bracket and set it at the desired angle +/- 20 degrees and use the Torx bit provided to tighten the security screw located at the top of the mounting bracket to securely attach and lock the camera to the mounting bracket.
---	--

Note:To be fully EMC/EMI compliant the installer/user needs clip the provided ferrites onto the Satellite Camera & Building cables after they have been passed through the conduit hole in the Illustra Control Unit enclosure box, the distance from the boot of the RJ45 connector is approximately 6 Inches (155mm) to allow a loop inside the box & the ferrites to sit in the free alongside the PCB's.

- End -

Procedure 2 Control Unit installation

To set up your Illustra Insight control unit, complete the following steps:

1	Hold the control unit up against the mounting surface and mark out the four control unit (screw) holes on the mounting surface.
2	Evaluate the mounting surface and select appropriate fixings, if required drill four holes for the four plastic screw anchors.
3	Hold the control unit up to the mounting surface and align the four holes on the control unit with the four holes on the mounting surface.
4	Insert four screws of a minimum of 4.2mm diameter into the four holes and securely attach the control unit to the mounting surface.

Note:To be fully EMC/EMI compliant the installer / user needs to connect an electrical earth connection to the earth mounting stud on the inside of the control unit metal box.

Procedure 3 Hardware setup

Step	Action
1	To set up your Illustra Insight hardware, connect the Satellite Camera Module through its connector (F) (Figure 5) to the Satellite Camera Connector (D) (Figure 3) on the ICU with the 10m S/FTP CAT6 cable provided.

Note: To ensure the correct operation of the camera, alternative S/FTP CAT6 cables should not be used.

- 2 Connect the Illustra Control Unit to an IEEE 802.3bt power source (A). (40W minimum).
- 3 Optional: Connect a Wiegand Interface (C) (Figure 3) or OSDP Interface (B) (Figure 3) for Access Control Integration.

Figure 7 Control Panel Door Map Label

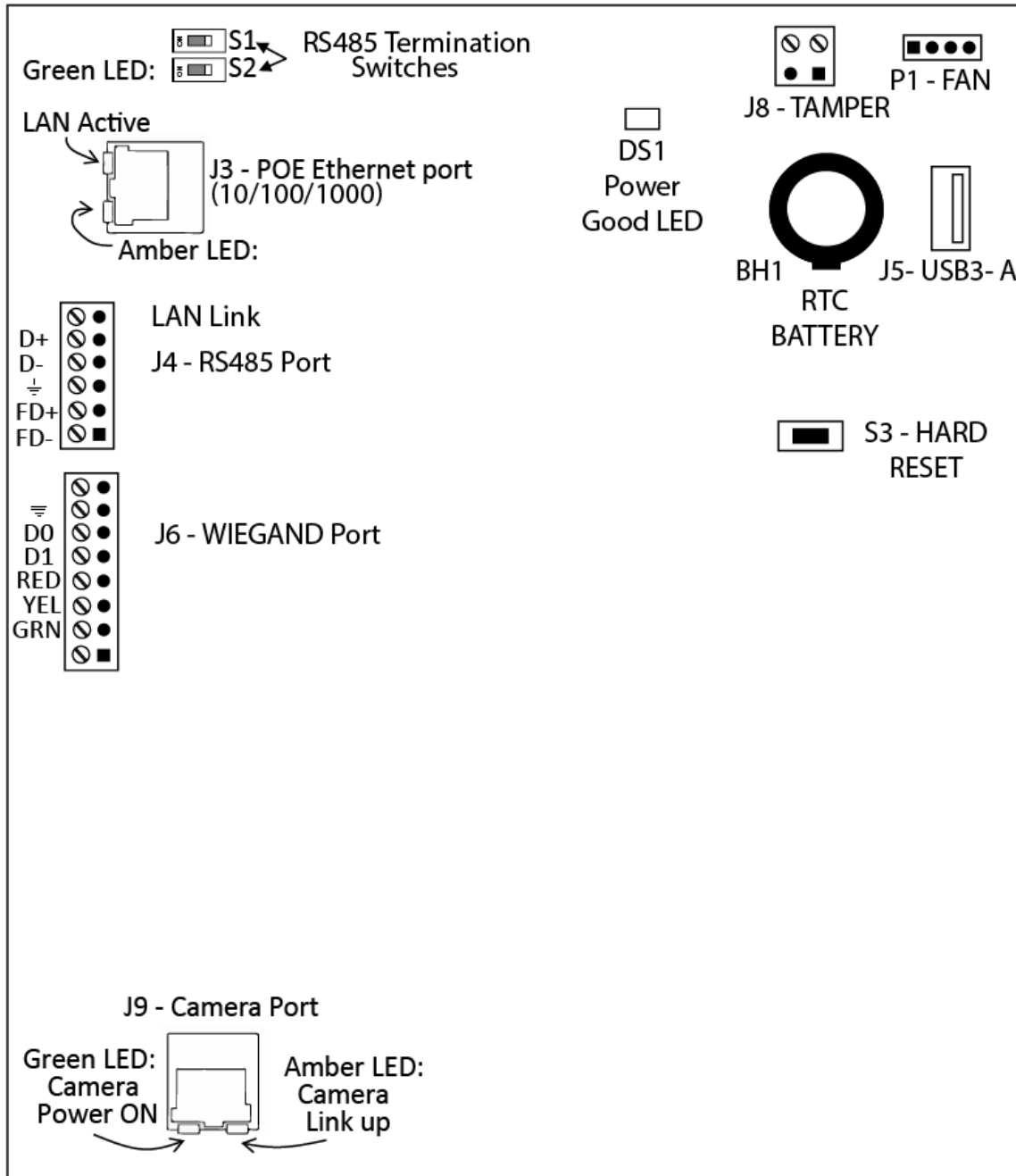

Figure 8 Wiegand Port Descriptions

Connector J6	Type	Signal	Description
⏏	⊘ ■	No connection	
	⊘ ●	Ground	GND
D0	⊘ ●	Output	D0
D1	⊘ ●	Output	D1
RED	⊘ ●	Input	Red
YEL	⊘ ●	Input	Yellow
GRN	⊘ ●	Input	Green
	⊘ ●	No connection	

Figure 9 RS485 / OSDP Port Descriptions

Connector J4	Type	Signal	Description
D+	⊘ ■	No connection	
	⊘ ●	Bidirectional	TXD/RXD+
D-	⊘ ●	Bidirectional	TXD/RXD-
⏏	⊘ ●	Ground	GND
FD+	⊘ ●	Input	RXD+
FD-	⊘ ●	Input	RXD-

Figure 10 Tamper Switch Descriptions

Connector J8	Type	Signal	Description
⊘ ●	⊘ ●	Ground	GND
	⊘ ■	Input	IN

Procedure 4 Network Configuration

Step	Action
------	--------

- | | |
|---|--|
| 1 | To configure your Illustra Insight Camera network, access the camera web GUI using <a href="http://<ipaddress>">http://<ipaddress> |
|---|--|

Note: Camera will automatically redirect user to using HTTPS communication.

- | | |
|---|--|
| 2 | From the View Selection, select Setup. |
| 3 | Select Network from the Setup menu and configure the network parameters as required. |
| 4 | Click Apply to apply the new network settings. |

Note: The camera then reboots.

Streaming live video

The Illustra Insight Camera supports RTSP streaming of H.264 encoded live video. To use this feature, a video streaming client can be used. To access the live video, use the following URL:
 rtsp://<ipaddress>/live_video

Note:The <ipaddress> is the IP address of the Illustra Insight Camera.

Procedure 5 Capturing a raw snapshot

The Raw snapshot download button lets you save a snapshot of the FoV to file in RAW format. After you configure your camera settings, you can capture a raw snapshot in UYVY format.

Step	Action
1	Access the camera web GUI using http://<ipaddress>
2	From the View Selection, select Setup.
3	Select System from the Setup menu and then select Raw Snapshot.
4	Click the Download button to capture a snapshot. The snapshot is automatically downloaded in approximately 3 seconds.

- End -

Access control system interface

Option 1: Wiegand

The Control Unit implements a standard Wiegand Interface to interface to an Access Control System. By default, the camera is configured to output a MIFARE 32-bit compatible signal to communicate a card number via Wiegand.

Procedure 6 Configuring the Wiegand interface

Step	Action
1	Connect a standard Wiegand interface cable to the Wiegand Interface (C)

Note:The hardware and firmware use the D0/D1 and RED, YELLOW, GREEN signals.

Note:The access control system requires a 5V 'pull up resistor' on each of the two Wiegand data signals (D0 and D1) to operate with the Insight camera. The resistors should be in the 470 ohm to 6000 ohm range.

2	Access the camera web GUI using http://<ipaddress>.
3	From the View Selection, select Setup.
4	Select Frictionless Access from the Setup menu and then select Test.
5	Enter an example card number as a base 10 integer (e.g. 65005).
6	Click the Send button to send the card ID via Wiegand.

- End -

If the target access control system is configured with the card numbers that are being sent, then the LED ring on the Camera Head will reflect the Access Granted/Access Denied status as indicated via the Wiegand RED and GREEN status lines.

Option 2: OSDP

Note:Firmware upgrade is required to support OSDP communication

The RS-485 connector / OSDP Interface (B) is for OSDP communication. Follow the same steps as on the previous page for OSDP Interface Integration.

Licensing

See www.illustracameras.com/insight for more information.

Camera firmware

The camera can be upgraded using firmware provided by Illustra.

All existing camera settings are maintained when the firmware is upgraded. You should only use firmware that has been provided by Illustra. Using any other firmware may cause a malfunction and damage the camera.

Procedure 7 Upgrading the camera firmware

Step	Action
------	--------

- | | |
|----|---|
| 1 | Select Setup on the Web User Interface banner to display the setup menus. |
| 2 | Select Maintenance from the Systems menu. |
| 3 | Select Browse. |
| 4 | Select Setup on the Web User Interface banner to display the setup menus. |
| 5 | Select Maintenance from the Systems menu. |
| 6 | Select Browse. |
| 7 | The Choose file to Upload dialog displays. |
| 8 | Navigate to the location where the firmware file has been saved. |
| 9 | Select the firmware file then select the Open button. |
| 10 | Select Upload. |

Do not disconnect power to the camera during the upgrade process. The camera restarts automatically after the updates have been completed, this can take from 1 to 10 minutes. The Log in page displays.

- End -

Managing cameras with the Illustra Connect tool

In addition to using the IE browser to access your camera, you can alternatively use the provided tool, Illustra Connect. Illustra Connect is a management tool designed to manage your network cameras on the LAN.

Used with Insight cameras, it can:

- Help you find multiple network cameras.
- Set the IP addresses.
- Show connection status.
- Manage firmware upgrades.
- Bulk configuration of networking, im Image settings, Partner IDs and config upload.

Additional Resources

Technical Support

Region	E-mail	Number
NA/SA	video-support@jci.com	1-800-507-6268 / 1-800-392-2873
EMEA	video-support@jci.com	+800-2255-8926 / +31-475-352-722
APAC	video-support@jci.com	+800-2255-8926 / +31-475-352-722

Licensing

Region	E-mail	Number
NA/SA	licenses@tycoint.com	1-978-577-4000
EMEA	video-support@jci.com	+31 475-352-722
APAC	video-support@jci.com	+31 475-352-722

SSA Sales Worldwide: tspsa@tycoint.com

Network Topology

The Illustra Insight camera delivers video images and audio in real-time using the internet and intranet. It is equipped with an Ethernet RJ-45 network interface.

The following images illustrate the network topologies of the camera.

Illustra Insight Camera Topology

Figure 11 Illustra Insight camera Network Topology Type I.

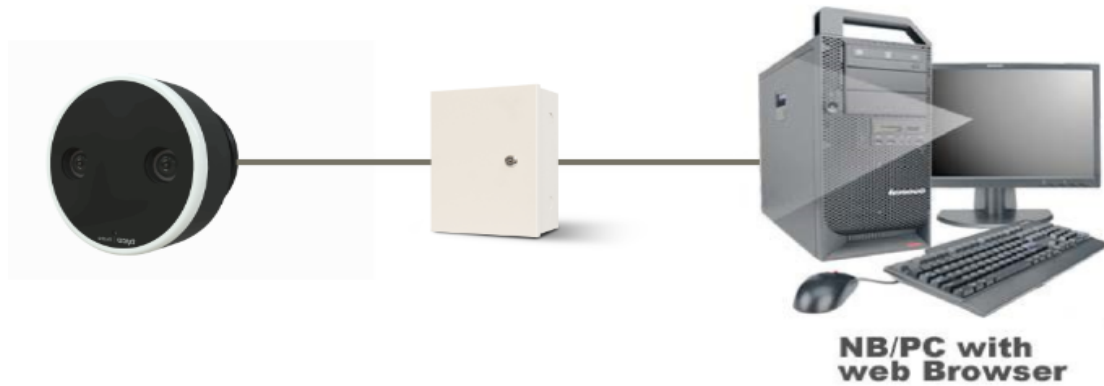
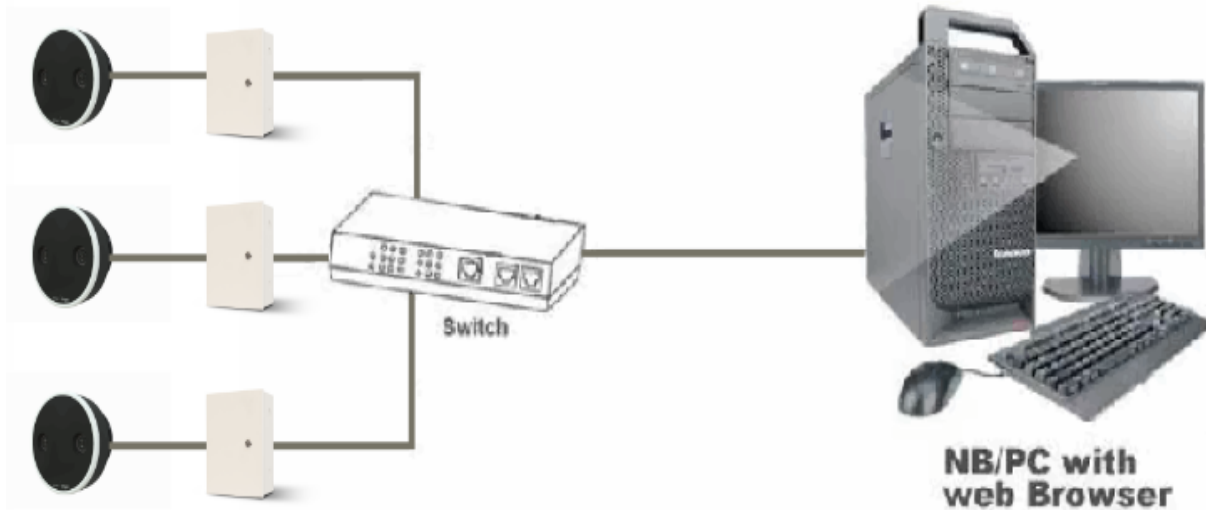

Figure 12 Illustra Insight cameras Network Topology Type II



Note: Please check your server specification for camera connection limits.

Illustra Insight Camera Topology

The Illustra Insight camera control unit delivers video images and audio in real-time using a network connection. It is equipped with an Ethernet RJ-45 network interface.

Figure 13 Illustra Insight camera integration with an Access Control system.

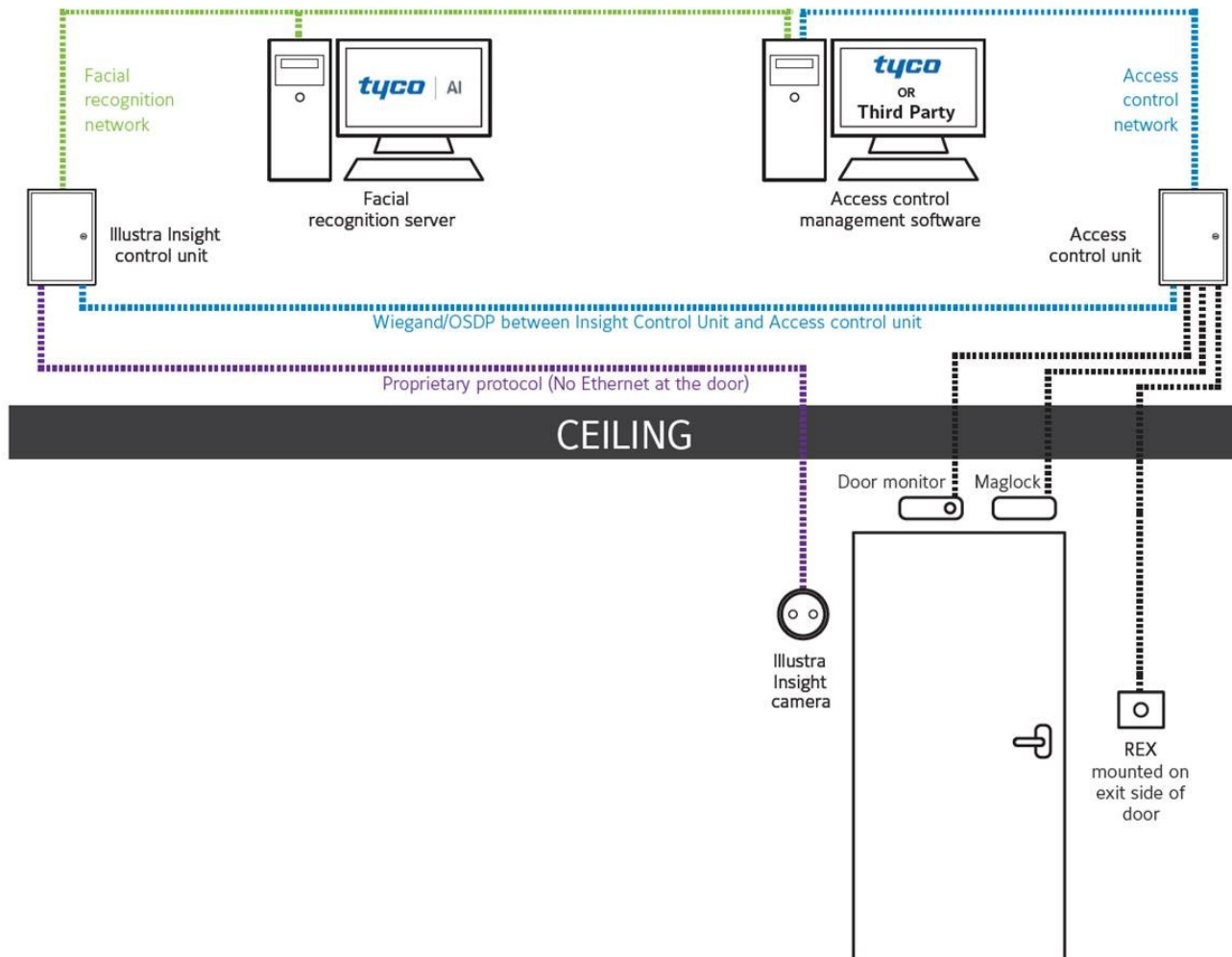

Illustra Insight integrates with Tyco AI and access control solutions to deliver an intelligent frictionless access experience.

Tyco AI is a cerebral engine that goes beyond surveillance and access to enhance a security ecosystem. Propriety protocols are used to ensure secure communications between the Insight camera and Insight control unit.

Illustra Insight is designed for seamless integration with Johnson Controls access brands, CEM Systems, Software House and Kantech. It is also access control agnostic and can be interconnected via traditional and modern wiring protocols into any access system panel that has on-board Wiegand or OSDP.

Network Connection

Default IP Address

Since this is a network-based unit, an IP address must be assigned at the very first bootup. The default IP address of the unit is 192.168.1.168 and sub mask is 255.255.255.0.

However, if you have a DHCP server in your network, the unit obtains an IP address automatically from the DHCP server so that you do not need to change the IP address of the camera.

Note: If you assign the camera a Static IP address prior to DHCP being enabled, the camera first reboots for approximately 30 seconds and then remains accessible at its Static IP until it connects to a DHCP server.

- Connect to a PC directly: Directly connect the camera to a PC using a standard Ethernet cable. This requires POE switch or injector.
- Connecting a camera to a Local Area Network (LAN): To add the camera to an existing LAN, connect the camera to the POE hub or switch on your network.

Figure 14 Network connection diagram

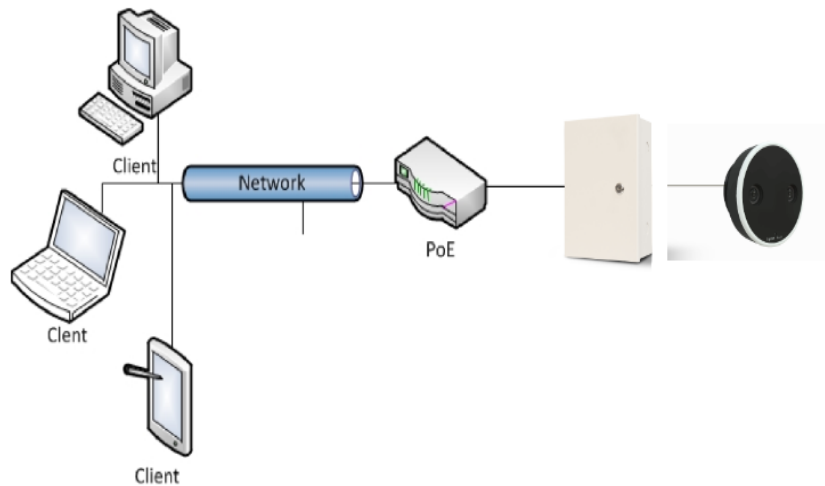

Default camera settings

The following table describes the default camera settings.

Network Settings	Defaults
DHCP	Enabled
Static IP Address	192.168.1.168
Default Username	admin
Default Password	admin

Procedure 8 Connecting from a computer

Step	Action
1	Ensure the camera and your computer are in the same subnet.
2	Check if the network is available between the unit and the computer by pinging the default IP address. <ol style="list-style-type: none"> a Start a command prompt. b Type "Ping 192.168.1.168". If the message "Reply from..." appears, it means the connection is available.
3	Start Internet Explorer and enter IP address: 192.168.1.168. A login window appears. In the window, enter the default user name: admin and password: admin to log in.

- End -

DHCP

On initial camera startup, and after a hardware factory reset, Dynamic Host Configuration Protocol (DHCP) is enabled by default and remains enabled until the camera receives either a DHCP address or is assigned a Static IP address.

Procedure 9 Enable DHCP

Step	Action
1	Select Setup on the Web User Interface banner to display the setup menus.
2	Select the TCP/IP tab in the Basic Configuration menu.
3	Select the Enable DHCP check box to enable DHCP and disable manual settings.
4	Select Apply to save the settings.

The camera searches for a DHCP server. If one is found it connects to that server. If no connection is made to a DHCP server within two minutes, the camera goes to the default IP address 192.168.1.168, but continues to search for a DHCP address.

Note: If you assign the camera a Static IP address prior to DHCP being enabled, the camera first reboots for approximately 30 seconds and then remains accessible at its Static IP until it connects to a DHCP server.

- End -

Procedure 10 Disable DHCP

Step	Action
1	Select Setup on the Web User Interface banner to display the setup menus.
2	Select the TCP/IP tab in the Basic Configuration menu.
3	Clear the Enable DHCP check box to disable DHCP and allow manual settings to be entered. The default setting is 'Enabled'.
4	If Enable DHCP has been disabled:

- a Enter the IPv4 Address in the **IPv4 Address** text box in the form xxx.xxx.xxx.xxx. The default setting is '192.168.1.168'
 - b Enter the Network Mask in the **Network Mask** text box xxx.xxx.xxx.xxx. The default setting is '255.255.255.0'
 - c Enter the Gateway IP address in **Gateway** text box xxx.xxx.xxx.xxx.
 - d Enter the Primary DNS Server in the **Primary DNS Server** text box xxx.xxx.xxx.xxx.
- 5 Select **Apply** to save the settings.

- End -

Managing cameras with the Illustra Connect tool

In addition to using the IE browser to access your camera, you can alternatively use the provided tool, Illustra Connect.

Illustra Connect is a management tool designed to manage your network cameras on the LAN. It can:

- help you find multiple network cameras
- set the IP addresses
- show connection status
- manage firmware upgrades
- bulk configuration

Refer to Configuration on page 1 for further information regarding using the Illustra Connect tool for configuring the cameras.

Procedure 11 Connecting to the camera using Illustra Connect

Note: Illustra Connect can only discover devices on the same subnet as its host computer. Therefore, the camera and the computer being used to configure it must be on the same subnet.

Step	Action
1	Using a computer which is connected to the same network and subnet, install the Illustra Connect software. The Illustra Connect software and the Illustra Connect manual are available to download on www.illustracameras.com
2	When the installation is complete, run Illustra Connect. It searches the network and displays all compliant devices.
3	Select the camera you want to configure, locating it by its unique MAC address.
4	Right-click the camera and select Launch Web GUI Configuration. The camera Web User Interface displays.

- End -

Procedure 12 Connecting to the camera using the static IP address

Step	Action
1	The camera attempts to obtain an IP Address from the DHCP Server. When no DHCP Server is available the camera is assigned a Static IP address of 192.168.1.168.
2	Open Microsoft Internet Explorer and enter the URL of the camera as 192.168.1.168. The camera sign in page displays.

Note:The computer you use to configure the camera must have an IP address on the same subnet.

- End -

Procedure 13 Logging on to the camera web user interface

Step	Action
1	When you select the camera, the sign in page displays. Select your preferred language from the drop-down menu.
2	Enter the username in the Username text box. The default username is admin.
3	Enter the password in the Password text box. The default password is admin.
4	Select Log in .

Note:The first time that you access the camera or after a factory reset the following pop up window is visible: A pop up window that requests the user to **Define a Host ID**. Please refer to the Release Notes for further information on this. **Define a Host ID:** The admin user must enter a 6 character code for the Host ID that includes both letters and / or numbers. This unique password can be used to access the operating system files. The HostID is not stored on the camera for security reasons and must be presented to Illustra Technical Support when remote access to the operating system is required.

5 Change the default credentials. A username and password change is mandatory.

Password requirements:

- Minimum eight characters.
- Have at least one character from each of the following character groups:
 - Upper-case letters - ABCDEFGHIJKLMNOPQRSTUVWXYZ
 - Lower-case letters - abcdefghijklmnopqrstuvwxyz
 - Numeric characters - 0123456789
 - Special characters - @%+V' !#\$^?.,(){]~-_`

6 The Live view page is visible. This displays the current view of the camera.

- End -

Procedure 14 Enabling the correct video orientation for a wall mounted camera

Step	Action
1	Log on to the camera web user interface.

- 2 Select **Setup** on the camera web user interface banner to display the setup menus.
- 3 Select the **Picture Basic** tab from the **Basic Configuration** menu.
- 4 Select the required **Orientation** setting:
 - **Mirror**
 - **Flip**
- 5 The video pane updates to display the new settings.

- End -

Configuration

The following sections explain the how you can configure Illustra Insight camera using the Web User Interface.

Accessing the Illustra Insight Series Camera Web User Interface

Use the following procedure to access the camera Web User Interface.

Procedure 15 Logging in to the Camera

Step	Action
1	Refer to Network Connection on page 18 for details on how to connect the camera to your network or computer.
2	When you select the camera, the sign in page displays.
3	Select your preferred language from the drop-down menu. The default language is English.
4	Enter the default username and password when prompted - Username: admin, Password: admin.
5	Click Log in . The camera Web User Interface displays. The first time that you access the camera, or after a factory reset, you are prompted to Define a Host ID . <ul style="list-style-type: none">• Define a Host ID: The admin user must enter a 6 character code for the Host ID that includes both letters and / or numbers. This unique-password can be used to access the operating system files. The HostID is not stored on the camera for security reasons and must be presented to Illustra Technical Support when remote access to the operating system is required.
6	Change the default credentials. A username and password change is mandatory. Password requirements: <ul style="list-style-type: none">• Minimum eight characters.• Have at least one character from each of the following character groups:<ul style="list-style-type: none">• Upper-case letters - ABCDEFGHIJKLMNOPQRSTUVWXYZ• Lower-case letters - abcdefghijklmnopqrstuvwxyz• Numeric characters - 0123456789• Special characters - @%+V' !#\$^?:() { } [] ~ - _ `
7	Once the above steps are complete, the Live view page is visible. This displays the current view of the camera.

- End -

Changing the Camera Web User Interface Language

Use the following procedure to change the language used in the camera Web User Interface.

Procedure 16 Change the Camera Web User Interface Language

Step	Action
1	Open the camera sign in page. If you are already logged in to the Web User Interface, select Log Off to display the sign in page.
2	Select your preferred language from the drop-down menu: <ul style="list-style-type: none">• English• Arabic• Czech• Danish• German• Spanish• French• Hungarian• Italian• Japanese• Korean• Dutch• Polish• Portuguese• Swedish• Turkish• Chinese Simplified• Chinese Traditional• Russian• Hindi The default language is English.
3	Enter the Username.
4	Enter the Password.
5	Select Log in.

The camera web User Interface displays in the selected language.

- End -

Live menu

When you log in to the Illustra Web User Interface, the **Live** menu appears, as seen in Figure 15 on page 25.

Figure 15 Live menu page



Displaying the Live View Page

Display the live camera view page.

Procedure 17 Display Live View Page

Step	Action
1	Select Live in the Web User Interface banner. The Live view page displays.
2	Select a percentage from Scale to change the display size of the video pane: <ul style="list-style-type: none">• 25%• 50%• 75%• 100% The default setting is 50%.

- End -

Accessing the Setup Menus from Live View

Setup menus within the Web User Interface are restricted by user account access levels. Refer to Appendix A: User Account Access on page 1 for details on the features which are available to each role.

Procedure 18 Access Setup Menus from Live View

Step	Action
------	--------

- 1 On the **Live** menu, click the **Setup** tab.

Note:When an admin user logs in for the first time the Liven menu displays. After this, on each login the Stream page on the Video menu displays.

- End -

Video Menu

When you select the **Video** menu, the **Picture Settings** page displays, as seen in Figure 16 on page 27.

Figure 16 Video Menu

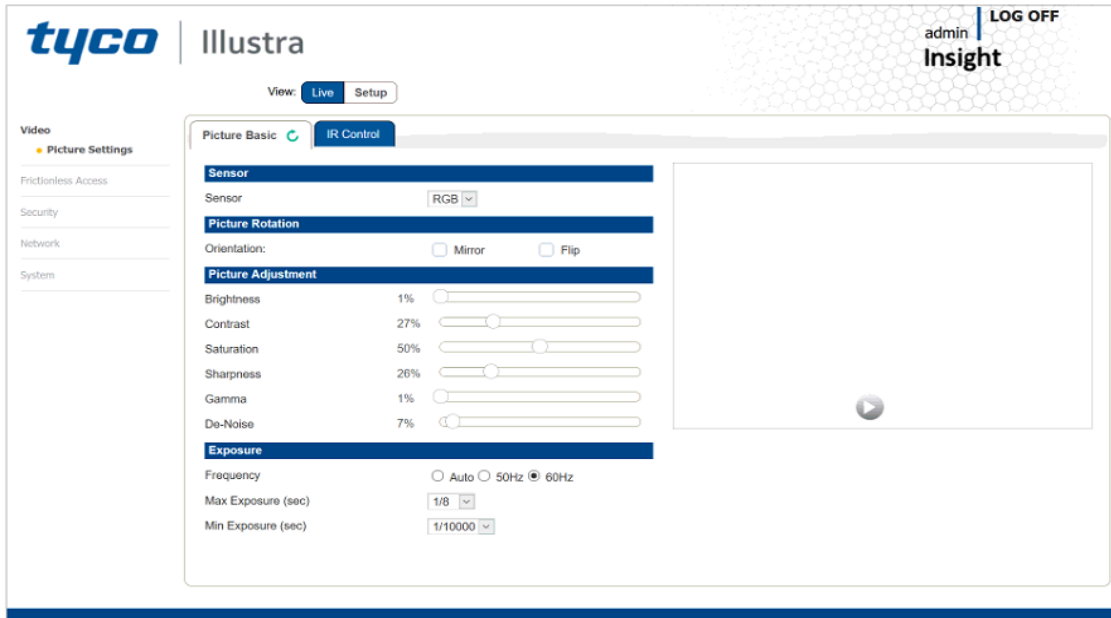

The **Video** Menu provides access to the following camera settings and functions:

- Picture Settings
- IR Control

Picture Settings

Picture Basic

Adjust the picture; Sensor, Rotation, Picture Adjustment and Exposure.

Sensor

Choose sensor mode to display & configure corresponding picture settings.

Procedure 19 Select the sensor settings

Step	Action
------	--------

- | | |
|---|---|
| 1 | Select Setup on the Web User Interface banner to display the setup menus. |
| 2 | Select the Picture Basic tab from the Video menu. |
| 3 | Select a Sensor option from the drop-down menu: <ul style="list-style-type: none">• RGB |

- IR

- End -

Picture Rotation

Configure the orientation and corridor mode settings. Both settings are optional.

Procedure 20 Configure the picture orientation

Step	Action
1	Select Setup on the Web User Interface banner to display the setup menus.
2	Select the Picture Basic tab from the Video menu.
3	Select the required Orientation setting: <ul style="list-style-type: none"> • Mirror • Flip Mirror and Flip settings are not selected by default. The video pane updates to display the new settings.
<p>Note:When wall mounting the Illustra Insight you should select Flip to correct the lens orientation.</p>	

- End -

Picture Adjustment

Adjust brightness, contrast, and saturation, sharpness, gamma, and de-noise of the image displaying on the video pane.

Procedure 21 Adjust the picture settings

Step	Action
1	Select Setup on the Web User Interface banner to display the setup menus.
2	Select the Picture Basic tab from the Video menu.
3	Select  to start the video stream if it is not already active. The video pane displays the current camera view.
4	Use the slider bars to adjust: <ul style="list-style-type: none"> • Brightness • Contrast • Saturation • Sharpness • Gamma • De-Noise The values range from 1% to 100%. The video pane updates to display the new settings.

- End -

Exposure

You can set the exposure setting to 50Hz or 60Hz or Auto.

Procedure 22 Configure the exposure settings

Step	Action
1	Select Setup on the Web User Interface banner to display the setup menus.
2	Select the Picture Basic tab from the Video menu.
3	Select  to start the video stream if it is not already active.
4	Select the Frequency radio button to Auto , 50Hz or 60Hz . The default setting is 60Hz.
5	Select the Max Exposure (sec) drop down menu.
6	Select the Min Exposure (sec) drop down menu.

- End -

IR Control

You can enable IR control and adjust its brightness.

IR Illuminator

When the camera is in B/W mode it can utilize or “see” near-IR illumination; something the human eye cannot do. This can be extremely powerful when the camera is paired with 850~950nm IR illuminators. With this combination a scene can be well lit with IR light that the camera can see but people cannot. This is great for areas where external lighting is not allowed or there is a need for covert security.

Procedure 23 Enable / disable IR Control

Step	Action
1	Select Setup on the Web User Interface banner to display the setup menus.
2	Select the IR Control tab from the Video menu.
3	Select the Enabled check box to enable IR Control . OR Clear the Enabled check box to disable IR Control . The default setting is 'Disabled'.

- End -

Procedure 24 Adjust the IR Control brightness

Step	Action
1	Select Setup on the Web User Interface banner to display the setup menus.
2	Select the IR Control tab from the Video menu.
3	Use the slider bars to adjust the Brightness. The values range from 1% to 100%.

- End -

Privacy Zones

Privacy Zones are “masked” sections of the camera’s viewing area. These masks prevent operators of the surveillance system who do not have access to the camera password from viewing these designated zones. Each zone has four sides, and the zones may overlap to form irregular shapes.

The apparent size of the Privacy Zone adjusts automatically as the zoom level is adjusted. Privacy Zones are useful for high security areas. For example, you might establish a privacy Zone around a safe’s combination, but still view people approaching or opening the safe.

Up to 12 rectangular privacy zones can be used on the camera.

Defining a Privacy Zone

Create a privacy zone on the camera.

Procedure 25 Define a Privacy Zone

Step	Action
1	Select Setup on the Web User Interface banner to display the setup menus.
2	Select Privacy Zones from the Video menu.
3	Select  to start the video stream if it is not already active. The video pane displays the current camera view.
	Note: For the PTZ camera navigate to the centre of the camera field of view to create a privacy zone.
4	Click on the edit pencil button. Click and drag on the camera picture to define an area for the privacy zone. For the PTZ camera you must click and drag from the centre of the camera field of view.
	Note: For the PTZ camera it is advised that you draw privacy zones larger than required to help ensure better coverage during the PTZ operations. This compensates for privacy zone distortion and repositioning during Pan, Tilt and Zoom.
5	Release the mouse button. The selected privacy area will turn yellow.
6	Select Add to save the current privacy zone.
7	To reselect an alternative area for the privacy zone select Cancel and repeat from step 4.
	Note: When a new privacy zone is created it is automatically enabled.

- End -

Enabling or Disabling a Privacy Zone

Select a privacy zone to hide or display on the camera. The PTZ camera does not support Enabling or Disabling a Privacy Zone, zones should be deleted and redrawn when necessary.

Procedure 26 Enable/Disable a Privacy Zone

Step	Action
1	Select Setup on the Web User Interface banner to display the setup menus.
2	Select Privacy Zones from the Video menu. The Privacy Zones tab displays.
3	Select  to start the video stream if it is not already active. The video pane displays the current camera view.
4	Select the corresponding Enabled check box to enable the privacy zone. OR Clear the corresponding Enabled check box to disable the privacy zone.

- End -

Deleting a Privacy Zone

Delete a privacy zone from the camera.

Procedure 27 Delete a Privacy Zone

Step	Action
1	Select Setup on the Web User Interface banner to display the setup menus.
2	Select Privacy Zones from the Video menu. The Privacy zones tab displays.
3	Select the corresponding Delete check box to mark the privacy zone for deletion.
4	Select Delete to delete the selected privacy zones.
5	You are prompted to confirm the deletion.
6	Select OK to confirm the deletion. OR Select Cancel .

- End -

Frictionless Access

When you select the **Frictionless Access** menu, the **Face Recognition** page displays, as seen in Figure 17 on page 32.

Figure 17 Frictionless Access

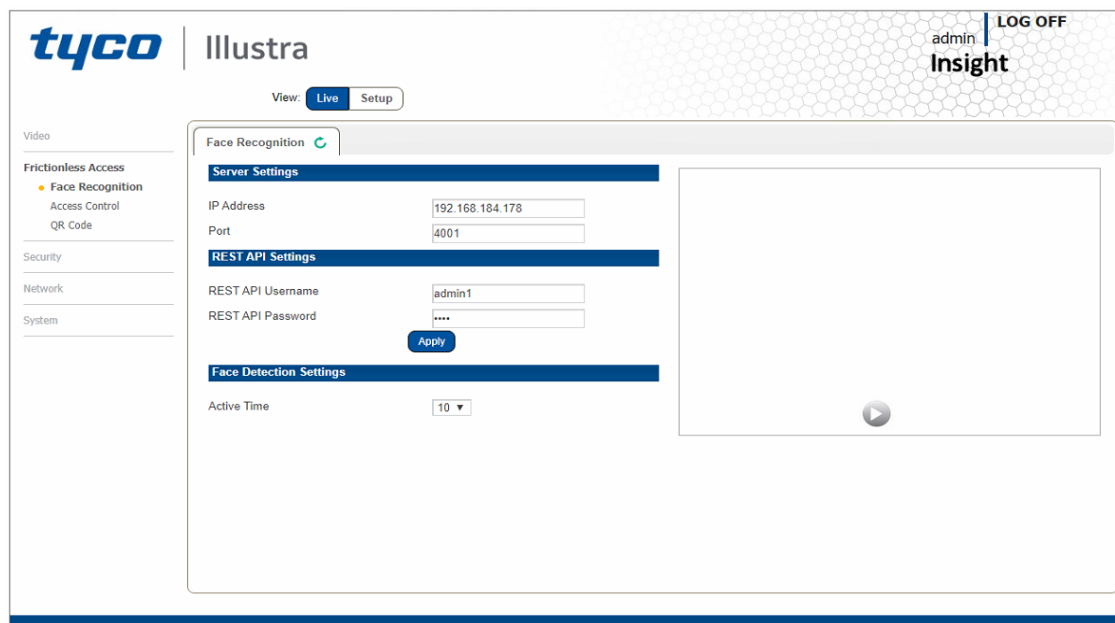

The **Frictionless Access** Menu provides access to the following camera settings and functions:

- Face Recognition
- Access Control
- QR Code

Frictionless Access

Face Recognition

You can view and edit the TycoAI facial server IP address, 4001 port, REST API settings and Face Detection settings.

Server Settings

You can view and edit the TycoAI facial server IP address and 4001 port.

Procedure 28 View or edit the TycoAI facial Server settings

Step	Action
1	Select Frictionless Access on the Web User Interface banner. The Face Recognition options are now visible. The Server IP Address and Port numbers are now visible.

- 2 Select the **IP Address** text box to enter an IP address.
- 3 Select the **Port** text box to enter the port number.

- End -

REST API Settings

REST API are the credentials the user would have configured during the TycoAI server initial configuration. These are required to enable event communication between TycoAI and the camera.

Procedure 29 Configure REST API Settings

Step	Action
1	Select Frictionless Access on the Web User Interface banner. The Face Recognition options are now visible.
2	Select the REST API Username text box to enter a username.
3	Select the REST API Password text box to enter a password. Password requirements: <ul style="list-style-type: none"> • Any alphanumerical values. • Special characters - ! \$ % ' () + , - . / : ; = ? @ [] _ { }
4	Select the Apply button and then OK to save the settings.

- End -

Face Detection Settings

You can view and edit the server settings and REST API settings. You can also select the Face Detection Settings active time.

Procedure 30 Configure Face Detection Settings

Step	Action
1	Select Frictionless Access on the Web User Interface banner. The Face Recognition options are now visible.
2	Select the Active Time drop down menu to select a value. Note: Active time is the smoothing time for an active person. When a person has been identified, it is the number of seconds before that person will be looked for again. The values range from 3 to 10 seconds.

- End -

Access Control

You can enable or disable access control and select an Wiegand or OSDP interface.

Procedure 31 Enable / disable Access Control

Step	Action
1	Select Frictionless Access on the Web User Interface banner. The Face Recognition options are now visible.
2	Select the Access Control tab from the Frictionless Access menu.
3	Select the Enabled check box to enable or disable Access Control.

Note:When you disable Access Control then you cant configure the Wiegand and OSDP settings.

- End -

Procedure 32 Set the Access Control interface to Wiegand or OSDP

Step	Action
1	Select Frictionless Access on the Web User Interface banner. The Face Recognition options are now visible.
2	Select the Access Control tab from the Frictionless Access menu.
3	Select the Enabled check box to enable or disable Access Control.
4	Select an option from the Interface drop-down menu. <ul style="list-style-type: none">• Wiegand• OSDP

- End -

Procedure 33 Configure the Wiegand access control settings

Step	Action
1	Select Frictionless Access on the Web User Interface banner. The Face Recognition options are now visible.
2	Select the Access Control tab from the Frictionless Access menu and then select the Wiegand tab to view the Wiegand options.
3	Select the Card Number Length drop-down menu and select an option.
4	Select the Output Base converter drop-down menu and select an option. This is set to hex or decimal for the camera to consider what format the card id is accepted.
5	Select the Reversed check box to enable or disable the playout of the binary bit stream if the Access Control System requires it.

- End -

Procedure 34 Configure the OSDP settings

Step	Action
1	Select Frictionless Access on the Web User Interface banner. The Face Recognition options are now visible.
2	Select the Access Control tab from the Frictionless Access menu and then select the OSDP tab to view the OSDP options.
3	Select the Address [2 hex digits] drop-down menu and select an option.
4	Select the Mode drop-down menu and select an option.
5	Select the Secure Key [32 hex digits] and enter the secure key.
- End -	

QR Code

Real time extraction of QR codes from the live video image. You can use QR codes for visitor recognition and auto enrolment.

Procedure 35 Enable / Disable the QR Code

Step	Action
1	Select Frictionless Access on the Web User Interface banner. The Face Recognition options are now visible.
2	Select the QR Code tab from the Frictionless Access menu.
3	Select the Enabled check box to enable or disable the QR code.
- End -	

Security

When you select the **Security** menu, the **Sessions Timeout** page appears, as seen in Figure 18 on page 36.

Figure 18 Security menu

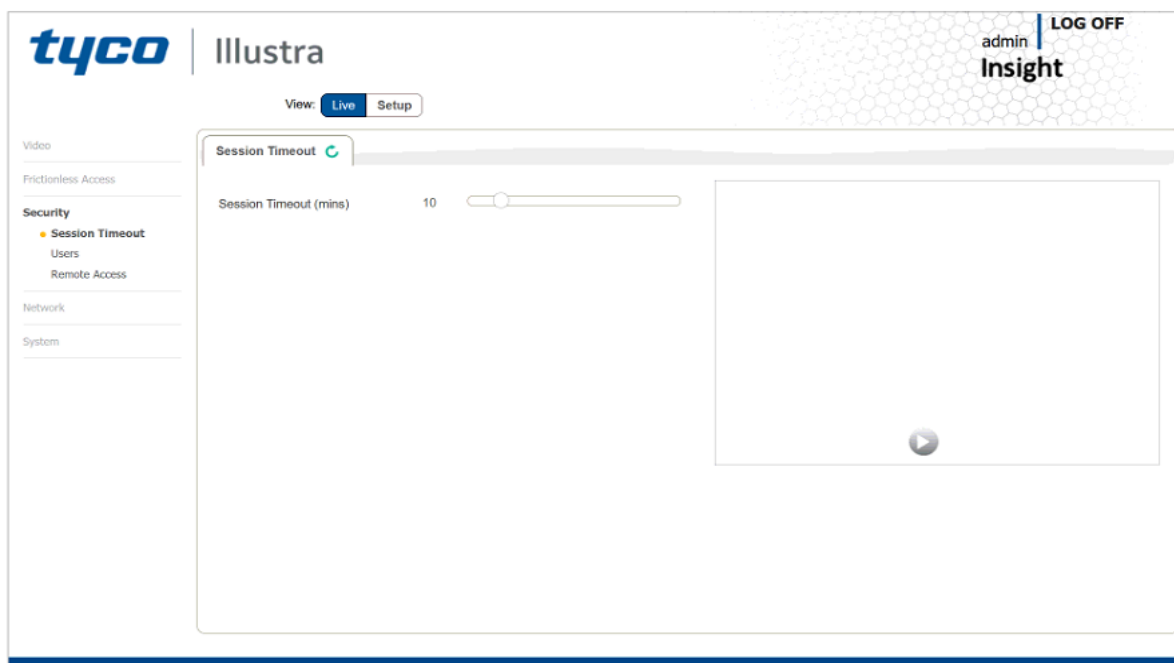

The Event Menu provides access to the following camera settings and functions:

- Session Timeout
- Users
- Remote Access

Session Timeout

Session timeout specifies the number of minutes that a web session can remain idle before it is automatically terminated.

Procedure 36 Set a Session Timeout time

Step	Action
1	Select Setup on the Web User Interface banner to display the setup menus.
2	Select Session Timeout from the Security menu. The Session Timeout tab displays.
3	Use the slider bar to select the Session Timeout (mins) . The default setting is 15 minutes.

- End -

Users

In this section you are able to add a user, change a user password and a delete user account.

Note: The default Username is **admin** and the default Password is **admin**. To maintain security the password on the admin account should be changed.

You must change the default password when first logging into the camera. See password requirements below:

- Minimum 8 characters
- Maximum 64 characters
- Must contain at least three from the following: lowercase, uppercase, digits, and punctuation. The following are not allowed when selecting a password: a space between letters / characters, |, <, >, :, comma, *, &, "
- Username must not form a substring of the password.
 - For example: a username and password combination of 'example' and 'example123' is not allowed.
- Passwords are compared against a short list of known common passwords, these are rejected when entered.
 - For example: 'Password1', while fulfilling previous requirements would be rejected.

View Current User Accounts

View a list of the current user accounts assigned to the camera.

Procedure 37 View User Accounts

Step	Action
1	Select Setup on the Web User Interface banner to display the setup menus.
2	Select Users from the Security menu. The current user accounts assigned to the camera display.
- End -	

Add User

Add a new user account to allow access to the camera.

Procedure 38 Add a User

Step	Action
1	Select Setup on the Web User Interface banner to display the setup menus.
2	Select Users from the Security menu.
3	Select the Add User tab.
4	Enter a User Name in the Name text box. The username must contain between 5 and 32 characters.
5	Enter a password in the Password text box.
6	Enter the same password in the Confirm Password text box.
7	Select Apply to save the settings.

The new user account is now visible in the Users list on the **Users** tab.

- End -

Changing the User Accounts Password

Change the password of an existing user account.

Procedure 39 Change User Password

Step	Action
------	--------

- | | |
|---|--|
| 1 | Select Setup on the Web User Interface banner to display the setup menus. |
| 2 | Select Users from the Security menu. |
| 3 | Select the Change Password tab. |
| 4 | Select the user account from the Name drop-down menu. |
| 5 | Enter the current password for the user account in the Current Password text box. |
| 6 | Enter the new password for the user account in the New Password text box.

You must change the default password when first logging into the camera. See password requirements below: <ul style="list-style-type: none">• Minimum 8 characters• Maximum 64 characters• Must contain at least three from the following: lowercase, uppercase, digits, and punctuation. The following are not allowed when selecting a password: a space between letters / characters, ,<,>, ;, comma, *, &, "
"• Username must not form a substring of the password.

For example: a username and password combination of 'example' and 'example123' is not allowed.• Passwords are compared against a short list of known common passwords, these are rejected when entered.

For example: 'Password1', while fulfilling previous requirements would be rejected. |
| 7 | Enter the same new password in the Confirm New Password text box. |
| 8 | Select Apply to save the settings. |

- End -

Delete a User Account

Delete a user account from the camera.

Note:The default 'admin' account cannot be deleted.

Procedure 40 Delete a User Account

Step	Action
------	--------

- | | |
|---|--|
| 1 | Select Setup on the Web User Interface banner to display the setup menus. |
| 2 | Select Users from the Security menu. |

The Users tab displays.

- 3 Select  to delete the corresponding user account.
You will be prompted to confirm the deletion.
- 4 Select **OK** to delete.
OR
Select **Cancel**.

- End -

Remote Access

In this section you can enable or disable SSH.

Procedure 41 Enable or disable SSH

Step	Action
1	Select Setup on the Web User Interface banner to display the setup menus.
2	Select Remote Access from the Security menu.
3	Select the Enabled check box to enable or disable SSH.

- End -

Network Menu

When you select the **Network** menu, the **TCP/IP** page displays, as seen in Figure 19 on page 40.

Figure 19 Network Menu

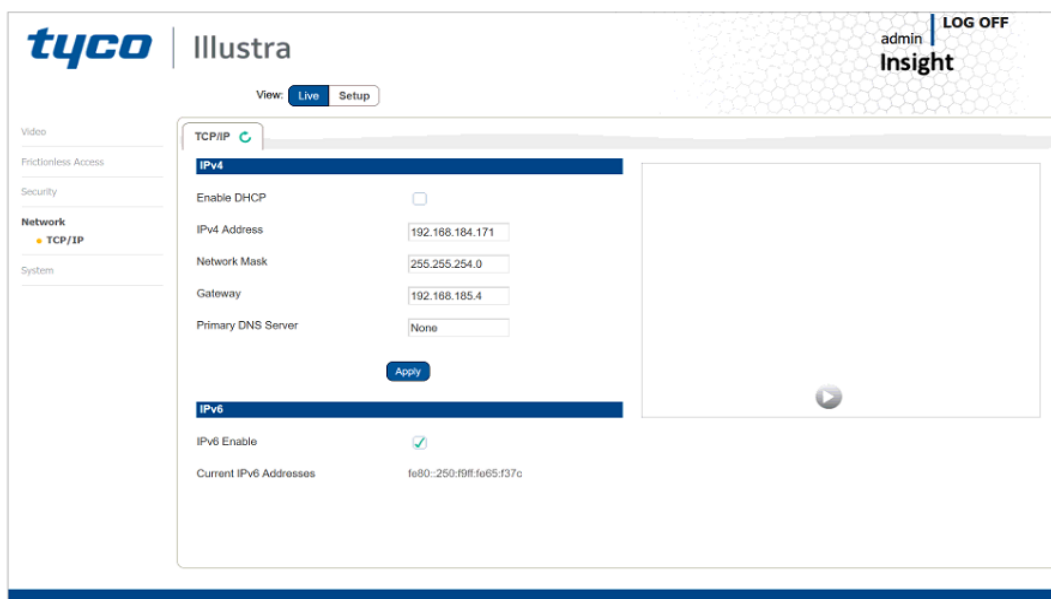

The Network Menu provides access to the following camera settings and functions:

- TCP/IP

TCP/IP

Configure the IPv4 and IPv6 settings on the camera.

IPv4

Configure the IPv4 settings for the camera.

Note: When you perform a factory reset or reboot the unit searches for the last known IP address. If this is not available it reverts to the default IP address of 192.168.1.168. This could result in duplicate IP addresses.

Procedure 42 Configure the IPv4 Settings

Step	Action
1	Select Setup on the Web User Interface banner to display the setup menus.
2	Select TCP/IP from the Network menu.
3	Select the Enable DHCP check box to enable DHCP and disable manual settings. OR Deselect Enable DHCP to disable DHCP and allow manual settings to be entered. The default setting is 'Disabled'.
4	If Enable DHCP has been disabled: <ol style="list-style-type: none"> Enter the IPv4 Address in the IPv4 Address text box in the form xxx.xxx.xxx.xxx. The default setting is '192.168.1.168' Enter the Network Mask in the Network Mask text box xxx.xxx.xxx.xxx. The default setting is '255.255.255.0' Enter the Gateway IP address in Gateway text box xxx.xxx.xxx.xxx. Enter the Primary DNS Server in the Primary DNS Server text box xxx.xxx.xxx.xxx.
5	Select Apply to save the settings.

- End -

IPv6

Enable IPv6 on the camera.

Procedure 43 Enable/Disable IPv6

Step	Action
1	Select Setup on the Web User Interface banner to display the setup menus.
2	Select TCP/IP from the Network menu.
3	Select the IPv6 Enable check box to enable IPv6 on the camera. OR Deselect the IPv6 Enable check box to disable IPv6 on the camera. The default setting is 'Enabled'. If IPv6 is enabled the Link Local and DHCP address displays beside 'Current IPv6 Addresses' if available.

- End -

System

When you open the **System** menu, the **Maintenance** page appears, as seen in Figure 20 on page 42.

Figure 20 System Menu

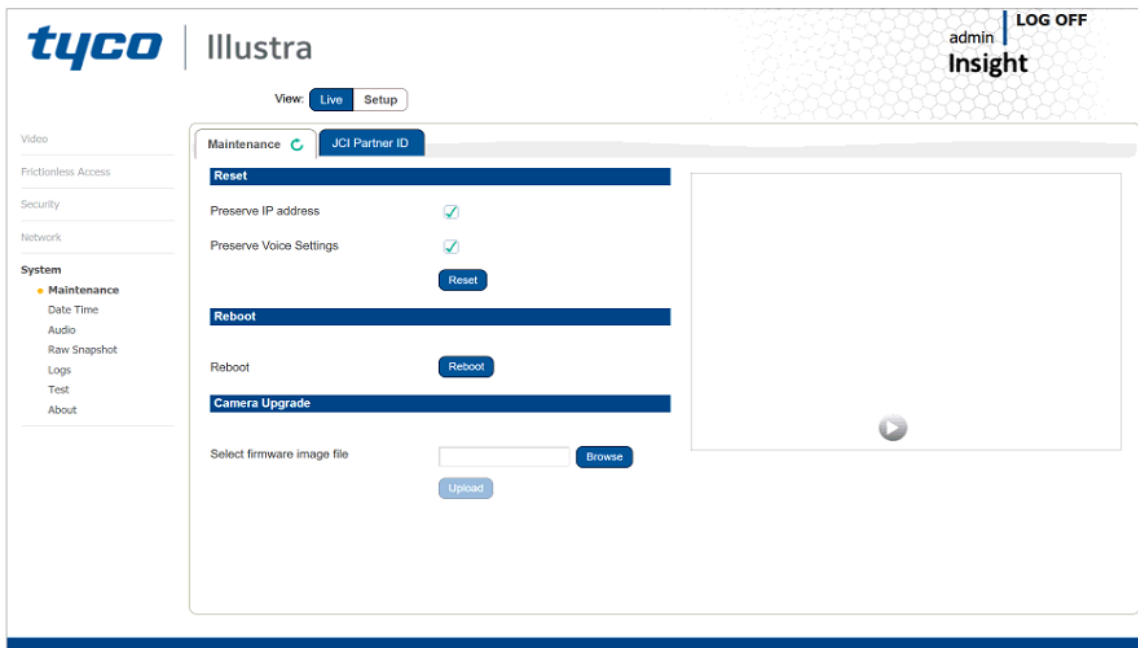

The System Menu provides access to the following camera settings and functions:

- Maintenance
- Date Time
- Audio
- Raw Snapshot
- Logs
- Test
- About

Maintenance

The Maintenance menu lets you to restore the camera settings to factory default, reboot the camera and apply a firmware upgrade. You can also apply the JCI partner ID.

Reset

To perform a physical reset of the camera, refer to the chapter regarding your camera model in this guide.

Note: Network settings can be retained if required.

Procedure 44 Resetting the Camera

Step	Action
1	Select Setup on the Web User Interface banner to display the setup menus.
2	Select Maintenance from the System menu.
3	Select the Preserve IP address check box to retain the current network settings during the camera reset. OR Deselect the Preserve IP address check box to restore the default networking settings. The default setting is 'Enabled'.
4	Select the Preserve Voice Settings check box to retain retain audio settings including audio licence and voice packs. OR Deselect the Preserve Voice Settings check box to restore the default audio settings including audio licence and voice packs. The default setting is 'Enabled'.
5	Select Reset . You will be prompted to confirm the camera reset. <ul style="list-style-type: none"> • Select OK to confirm. The Web User Interface will display a “Camera Resetting” page with a progress bar showing the reboot progress. • When the camera is restarted it will take 2 - 3 minutes until it is online and ready to be accessed and controlled. OR Select Cancel .
6	The Log in page displays.

- End -

Reboot

You can perform a physical reset of the camera.

Procedure 45 Reboot the Camera

Step	Action
1	Select Setup on the Web User Interface banner to display the setup menus.
2	Select Maintenance from the System menu.
3	Select Reboot . You will be prompted to confirm the camera reboot.
4	Select OK to confirm. The Web User Interface will display a “Camera Rebooting” page with a progress bar showing the reboot progress. When the camera is restarted it will take 2 - 3 minutes until it is online and ready to be accessed and controlled.

OR

Select **Cancel**.

5 The Log in page displays.

- End -

Camera Firmware Upgrade

The camera can be upgraded using firmware provided by Illustra.

Note:All existing camera settings are maintained when the firmware is upgraded.



Caution

You should only use firmware that has been provided by Illustra. Using any other firmware may cause a malfunction and damage the camera.

Procedure 46 Upgrade Camera Firmware

Step	Action
1	Select Setup on the Web User Interface banner to display the setup menus.
2	Select Maintenance from the System menu.
3	Select Browse . The Choose file to Upload dialog displays.
4	Navigate to the location where the firmware file has been saved.
5	Select the firmware file then select the Open button.
6	Select Upload . The file transfer will begin. Do not disconnect power to the camera during the upgrade process. The camera restarts automatically after the updates have been completed, this can take from 1 to 10 minutes. The Log in page displays.

- End -

Procedure 47 Applying a JCI partner ID

Step	Action
1	Select Setup on the Web User Interface banner to display the setup menus.
2	Select Maintenance from the System menu and then select the JCI Partner ID .
3	Select the Apply button to apply the Partner ID.

- End -

Date / Time

Set the date and time on the camera.

Note:When first powered up out of the box the camera synchronises with the date and time on the PC that is used to access the GUI.

Procedure 48 Configuring the Date and Time

Step	Action
1	Select Setup on the Web User Interface banner to display the setup menus.
2	Select the Date Time from the System menu.
3	Select the Time 24-hour check box to enable the 24-hour clock. Or Deselect the Time 24-hour check box to enable the 12-hour clock. The default setting is '24-hour'.
4	Select the Date Display Format from the drop-down menu: <ul style="list-style-type: none"> • DD/MM/YYYY • MM/DD/YYYY • YYYY/MM/DD The default setting is 'YYYY/MM/DD'.
5	Select the Time Zone from the drop-down menu. The default setting is '(GMT-05:00) Eastern Time (US & Canada)'
6	Select the Set Time setting by selecting the radio buttons: <ul style="list-style-type: none"> • Manually • via NTP The default setting is 'Manually'.
7	If you select Manually in step 5: <ol style="list-style-type: none"> a Select the Date (DD/MM/YYYY) using the drop-down menus. b Select the Time (HH:MM:SS) using the drop-down menus.
8	If you select via NTP in step 5: <ol style="list-style-type: none"> a Enter the NTP Server Name in the text box.

- End -

Audio

You can configure the audio output, upload audio and stored audio clips, as well as configure Audio Video Synchronization on this tab. Audio packs are sold separately and must be purchased prior to configuring audio.

Procedure 49 Configure Audio

Step	Action
1	Select Setup on the Web User Interface banner to display the setup menus.
2	Select Audio from the System menu.

- 3 Select the **Enable Audio** check box to enable the audio input settings.
Or
Clear the **Enable Audio** check box to disable audio input settings.
The default setting is 'Disabled'.
- 4 Use the slider bar to select the **Volume**.
Values range from 1 to 100.
The default setting is 72.

- End -

Procedure 50 Configure voice licenses

Step	Action
------	--------

- 1 Select **Setup** on the Web User Interface banner to display the setup menus.
- 2 Select **Audio** from the **System** menu and then select the **Audio License** tab.
- 3 Select the voice that you want to use from the **Voices** drop-down menu.

- End -

Procedure 51 Upload a voice pack

Different voice packs are available for the unit. These voice packs are grouped by geographical areas to provide an optimal set.

Step	Action
------	--------

- 1 Select **Setup** on the Web User Interface banner to display the setup menus.
- 2 Select **Audio** from the **System** menu and then select the **Audio License** tab.
- 3 Under the Upload Voice Pack heading select **Browse**.
The Choose file dialog displays.
- 4 Navigate to the location where the audio file has been saved.
Select the audio file then select the **Open** button.
- 5 Select **Upload**.
- 6 You will be prompted to confirm that you would like to upload the audio file.
Select **OK** to confirm the upload.
Or
Select **Cancel**.

- End -

Procedure 52 Upload a voice license

Step	Action
------	--------

- 1 Select **Setup** on the Web User Interface banner to display the setup menus.
- 2 Select **Audio** from the **System** menu and then select the **Audio License** tab.
- 3 Under the Upload Voice License heading select **Browse**.

- The Choose file dialog displays.
- 4 Navigate to the location where the audio file has been saved.
Select the audio file then select the **Open** button.
 - 5 Select **Upload**.
 - 6 You will be prompted to confirm that you would like to upload the audio file.
Select **OK** to confirm the upload.
Or
Select **Cancel**.

- End -

Raw Snapshot

Procedure 53 Upload a voice license

Step	Action
1	Select Setup on the Web User Interface banner to display the setup menus.
2	Select Raw Snapshot from the System menu.
3	Under the Download button to capture a snapshot. The snapshot is automatically downloaded.

- End -

Logs

Information is provided on system and boot logs created by the camera.

System Log

The system log gives the most recent messages from the `unix/var/log/messages` file. Information will include the following:

- Messages about system behavior such as process startup/shutdown.
- Warnings about recoverable problems that processes encounter.
- Error messages where processes encounter problems they cannot fix; note that this does not mean that the process will not continue to work, only that it encountered an issue it could do nothing about.

Procedure 54 Download System Log

Step	Action
1	Select Setup on the Web User Interface banner to display the setup menus.
2	Select Logs from the System menu.
3	Select the System Log Download button to view the logs.
4	Select Refresh to refresh the log for the most up-to-date information.

- End -

Application Log

Application logs provide important information for our support team to investigate possible issues.

Procedure 55 Download Application Log

Step	Action
1	Select Setup on the Web User Interface banner to display the setup menus.
2	Select Logs from the System menu.
3	Select the Application Log Download button to view the logs.
4	Select Refresh to refresh the log for the most up-to-date information.

- End -

Supervisor Log

Supervisor logs provide important information on what processes are running under supervisorctl.

Procedure 56 Download Supervisor Log

Step	Action
1	Select Setup on the Web User Interface banner to display the setup menus.
2	Select Logs from the System menu.
3	Select the Supervisor Log Download button to view the logs.
4	Select Refresh to refresh the log for the most up-to-date information.

- End -

Test

Procedure 57 Testing the LED

Step	Action
1	Select Setup on the Web User Interface banner to display the setup menus.
2	Select Test from the Systems menu to view the Test tab.
3	Select the Test button to test the LED.

Note: The camera runs a light sequence to validate that the LED's are working.

- End -

Procedure 58 Testing the Audio

Step	Action
1	Select Setup on the Web User Interface banner to display the setup menus.

- 2 Select **Test** from the **Systems** menu to view the Test tab.
- 3 Select the **Audio** button to test the Audio.

Note: The camera plays a test audio file to verify that the audio is working.

- End -

About

The About menu provides the following camera information:

- MAC Address
- Firmware Version

Appendix A: Using Media Player to View RTSP Streaming

Note: This appendix is provided for user instruction only. Tyco Security Products does not support or is not responsible for any error caused during the use of third party software used for RTSP playback.

Procedure 59 Viewing RTSP Stream through Media Player

Step	Action
------	--------

You can use Media Player to view live video in real time from the camera.

- 1 Select **Media** then **Open Network Stream**.
- 2 Enter the IP address of the camera stream in the **Network URL** text box in the following format to view Stream 1.
 - **Stream 1:** rtsp://IP_Address/live_videoFor example: rtsp://192.168.1.168:554/live_video
- 3 Select **Play**. The live video stream displays.

- End -

Appendix B: Camera Defaults

The below table details the defaults for the Web User Interface.

Table 21 Camera Defaults

Tab	Item	Default		
Picture Basic				
	Orientation	OFF		
	Brightness	50%		
	Contrast	50%		
	Saturation	50%		
	Sharpness	50%		
	Gamma	50%		
	De-Noise	50%		
	Exposure	60Hz		
IR Control				
	Enabled	Off		
	Brightness	100%		
Face Recognition				
	IP Address	-		
	Port	-		
	Rest API username	-		
	Rest API Password	-		
Access Control				
	Enabled	Selected		
	Interface	Wiegand		
	Card Number Length			
	Output Base Converter			

Tab	Item	Default		
	Reversed			
QR Code				
	Enabled	Selected		
Session Timeout				
	Session Timeout (mins)	15		
Users				
Add Users				
	Name	Unspecified		
	Role	admin		
	Password	Unspecified		
	Confirm Password	Unspecified		
Change Password				
	Name	admin		
	Current Password	Unspecified		
	New Password	Unspecified		
	Confirm New Password	Unspecified		
TCP/IP				
	Enable DHCP	ON		
	IPv4 Address	192.168.1.168		
	Network Mask	255.255.255.0		
	Gateway	Unspecified		
	Primary DNS	Unspecified		
Maintenance				
	Reserve IP Address			
	Reboot	Unspecified		
	Select Firmware file image	Unspecified		

Tab	Item	Default		
Date Time				
	Camera Time	N/A		
	Time 24 hour	Selected		
	Date Display Format	YYYY/MM/DD		
	Time Zone	GMT-05:00) Eastern Time US and Canada)		
	Set Time	via NTP		
	NTP Server Name	Unspecified		
Audio				
	Enable Audio	Disabled (Subject to license)		
	Volume	50%		
Audio License				
	Voices	-		
	Upload Voice Pack	Unspecified		
	Upload Voice License	Unspecified		
Link				
	Data Bits	8		
	Stop Bits	1		
	Parity	None		
	Baud	9600		
OSDP				
	OSDP Address	0		
	Secure Key Enable	Selected		
	Secure Key			
Raw Snapshot				
	Download	N/A		
Logs				
	System Log	N/A		
	Aplication Log	N/A		

Tab	Item	Default		
Test				
	Led			
	Audio			
Model				

Appendix C: Technical Specifications

The table below lists technical specifications of the Illustra Insight 2MP camera.

General Features	
Model Type	Illustra Insight Intelligent Frictionless Access Camera
Model No.	II-AN00INT01
Housing Color	Satellite Camera Module: Black Control Unit: Beige
Power	Power over Ethernet IEEE 802.bt Type 3 Class 5 (Max Draw: 40W)
Physical Features	
Dimensions (H x W x D)	Satellite Camera Module: 4.1 x 4.1 x 2.2 in (104 x 104 x 56mm) Control Unit: 10.2 x 7.3 x 4.3 in (260 x 187 x 109mm)
Operating Temperature	Satellite Camera Module: - 0.37kg Control Unit: - 2.2kg
Weight	Satellite Camera Module: - 4°F to 104°F (- 20°C to 40°C) Control Unit: - 25°F to 104°F (- 31.8°C to 40°C)
Humidity	0 to 90% Non Condensing
Plenum Rated - Control Unit	Yes
IP Rating	Satellite Camera Module: IP40 Control Unit: IP40
Configuration Management	
Web Browsers	IE9 & above, Firefox, Safari, Chrome
Security	Secure Boot; TLS 1.2 (256 bit cipher minimum); Role-Based Access Control
Regulatory	
Safety	EN62368-1
Emissions	FCC CFR 47 Part 15 Class A; EN55032 Class A; ICES-003
Fire Plenum Rated	UL-2043; CAN / ULC S142
Immunity	EN50130-4; EN 61000-3-2; EN 61000-3-3
Environment	RoHS, WEEE
Network	
Ethernet Interface	10/100/1000Mbps (Base T), RJ45, Auto-Negotiation
Supported Protocols	TCP/IP, IPV4, TCP, UDP, HTTP, DHCP, DNS, DDNS, RTP, TLS, RTSP, ICMP, Unicast, NTP, WS-Security, CIDS, FTSP, UPnP, SIP
Satellite Camera Connection	Cat6 Shielded patch cable, Max distance 10 meters, dd proprietary protocol
Access Control Interface 1	Wiegand (D0, D1, LED Rd, Yel, Gn) Cable Type - Belden 6543PA or equivalent

Access Control Interface 2	OSDP V2 (RS485 Half Duplex) Cable Type - Belden 82723 or equivalent
Operational	
Video Compression	H.264 & MJPEG
Max Frame Rate	2MP @ 20fps
Resolution & Aspect Ratio	1920x1080 (1080p) 16:9 Stereo or 3840x1080
Video Streams	Single or Dual Concatenated
Imager	Progressive Scan, CMOS, 1/3.2" 13MP (4:3)
Image Orientation Settings	None, Mirror, Flip, Flip & Mirror
Lens Type	Fixed, Fixed Iris / Aperture 2.8mm
Focus Control	Fixed
Minimum Illumination Lens Aperature	F2.8
Field of View (HxV)	85° / 63°
Shutter Speed	1/4 - 1/10,000
IR Illumination	Yes
IR Distance	2 metres
IR Filter wavelength	850nm
Dynamic Range	69dB
Day/Night	Dual Concatenated only
Privacy Zones	3
ONVIF Compliant	No
Video Intelligence Analytics	No
Motion Detection Zones	No
Face Detection	No
Face Recognition	Through Tyco AI or Cloud Service
Turnstyle Mode	Yes
Analogue Input / Output	No
Analogue Video Output	No
Audio	Bi-Directional Full Duplex
Simultaneous Users	3
Supported Languages	English, Arabic, Czech, Danish, German, Spanish, French, Hungarian, Italian, Japanese, Korean, Dutch, Polish, Portuguese, Swedish, Turkish,

	Chinese Simplified, Chinese Traditional, Russian, Hindi, Russian
--	--

Standards and Compliance

CE Marking

Hereby, American Dynamics declares that this equipment, if used according to the instructions, is in compliance with the essential requirements and other relevant provisions of the RTTE Directive 1999/5/EC. For use in all countries of the EU.

A Declaration of Conformity exists for the Illustra Insight readers. You can obtain a copy from Illustra.

Address:

Illustra,

6600 Congress Avenue

Boca Raton, FL 33487 U.S.A.

In case of alteration of the product, not agreed to by us, this declaration will lose its validity.

This symbol indicates proof of conformity to applicable European Economic Community Council directives and harmonized standards published in the official journal of the European Communities.



FCC Digital Device Limitations

Radio and Television Interference

This equipment has been tested and found to comply with the limits for a digital device, pursuant to Part 15 of the FCC rules. These limits are designed to provide reasonable protection against harmful interference when the equipment is operated in a commercial environment. This equipment generates, uses, and can radiate radio frequency energy and, if not installed and used in accordance with the instruction manual, may cause harmful interference to radio communications. Operation of this equipment in a residential area is likely to cause harmful interference, in which case the user will be required to correct the interference at his own expense.

Operation is subject to the following two conditions: (1) This device may not cause harmful interference, and (2) this device must accept any interference received, including interference that may cause undesired operation.

In order to maintain compliance with FCC regulations, shielded cables must be used with this equipment. Operation with non-approved equipment or unshielded cables is likely to result in interference to radio and television reception.

Note: Changes or modifications not expressly approved by the manufacturer could void the user's authority to operate this equipment and could create a hazardous condition.

Canadian Radio Emissions Requirements

This Class A digital apparatus complies with Canadian ICES-003.

Cet appareil numérique de la classe A est conforme à la norme NMB-003 du Canada.

UL Standards Compliance

The Insight Reader has been testing to the requirements of UL-2043 and CAN/ULC-S142 and test results have determined that the Insight is suitable for installation in air-handling spaces per these requirements.

Safety	EN 62338-1
Emissions	FCC CFR 47 Part 15 Class A ICES-003 EN 55032 Class A
Immunity	EN 50130-4 EN 61000-3-2 EN 61000-3-3
Fire Plenum Rating	UL-2043 CAN/ULC S142
Enclosure	IP4x
Environmental	RoHS WEEE

End User License Agreement (EULA)

IMPORTANT - READ THIS END-USER LICENSE AGREEMENT ("EULA") CAREFULLY BEFORE OPENING THE DISK PACKAGE, DOWNLOADING THE SOFTWARE OR INSTALLING, COPYING OR OTHERWISE USING THE SOFTWARE. THIS EULA IS A LEGAL AGREEMENT BETWEEN YOU AND SENSORMATIC ELECTRONICS, LLC ("TYCO"), AND GOVERNS YOUR USE OF THE SOFTWARE AND/OR FIRMWARE ACCOMPANYING THIS EULA WHICH SOFTWARE MAY BE INCLUDED IN AN ASSOCIATED PRODUCT AND INCLUDES COMPUTER SOFTWARE AND MAY INCLUDE MEDIA, PRINTED MATERIALS, AND "ON-LINE" OR ELECTRONIC DOCUMENTATION (COLLECTIVELY, THE "SOFTWARE"). BY BREAKING THE SEAL ON THIS PACKAGE, DOWNLOADING THE SOFTWARE OR INSTALLING, COPYING OR OTHERWISE USING THE SOFTWARE, YOU AGREE TO BE BOUND BY THE TERMS OF THIS EULA. IF YOU DO NOT AGREE TO ALL OF THE TERMS AND CONDITIONS OF THIS EULA, DO NOT OPEN, DOWNLOAD, INSTALL, COPY OR OTHERWISE USE THE SOFTWARE.

1. SCOPE OF LICENSE. The Software may include computer code, program files and any associated media, hardware or software keys, printed material and electronic documentation. The Software may be provided to you pre-installed in a product or on a storage device (the media) as part of a computer system or other hardware or device ("System"). The Software is protected by copyright laws and international copyright treaties, as well as other intellectual property laws and treaties. All title and intellectual property rights in and to the Software (including but not limited to any images, photographs, and text incorporated into the Software), the accompanying printed materials, and any copies of the Software, are owned by Tyco and/or its suppliers. The Software is licensed, not sold. All rights not expressly granted under this EULA are reserved by Tyco and its suppliers.

2. GRANT OF LICENSE. This EULA grants you the following rights on a non-exclusive basis:

a. General. This EULA permits you to use the Software for which you have purchased this EULA. If the Software is protected by a software or hardware key or other device, the Software may be used on any computer on which the key is installed. If the key locks the Software to a particular System, the Software may only be used on that System.

b. Locally Stored Components. The Software may include a software code component that may be stored and operated locally on one or more devices. Once you have paid the required license fees for these devices (as determined by Tyco in its sole discretion), you may install and/or use one copy of such component of the Software on each of the devices as licensed by Tyco. You may then use, access, display, run or otherwise interact with ("use") such component of the Software in connection with operating the device on which it is installed solely in the manner set forth in any accompanying documentation or, in the absence of such, solely in the manner contemplated by the nature of the Software.

c. Remotely Stored Components. The Software may also include a software code component for operating one or more devices remotely. You may install and/or use one copy of such component of the Software on a remote storage device on an internal network with all of the devices and may operate such component with each device over the internal network solely in the manner set forth in any accompanying documentation or, in the absence of such, solely in the manner contemplated by the nature of the Software; provided however, you must still acquire the required number of licenses for each of the devices with which such component is to be operated. d. Embedded

Software/Firmware. The Software may also include a software code component that is resident in a device as provided by Tyco for operating that device. You may use such component of the Software solely in connection with the use of that device, but may not retrieve, copy or otherwise transfer that software component to any other media or device without Tyco's express prior written authorization.

e. Backup Copy. You may make a back-up copy of the Software (other than embedded software) solely for archival purposes, which copy may only be used to replace a component of the Software for which you have current valid license. Except as expressly provided in this EULA, you may not otherwise make copies of the Software, including the printed materials.

3. OTHER RIGHTS AND LIMITATIONS. Your use of the Software is subject to the following additional limitations. Failure to comply with any of these restrictions will result in automatic termination of this EULA and will make available to Tyco other legal remedies.

a. Limitations on Reverse Engineering and Derivative Works. You may not reverse engineer, decompile, or disassemble the Software, and any attempt to do so shall immediately terminate this EULA - except and only to the extent that such activity may be expressly permitted, notwithstanding this limitation, either by applicable law or, in the case of open source software, the applicable open source license. You may not make any changes or modifications to any portion of the Software, or create any derivative works, without the written permission of an officer of Tyco (except as provided in Section 3(f) of this EULA with respect to "open source" software). You may not remove any proprietary notices, marks or labels from the Software. You shall institute reasonable measures to ensure compliance with the terms and conditions of this EULA by your personnel and agents.

b. Copyright Notices. You must maintain all copyright notices on all copies of the Software.

c. Transfer. You may only transfer your rights under this EULA (i) as part of a permanent sale or transfer of all of the devices for which the Software is licensed as applicable; (ii) if you transfer all of the Software (including all component parts, the media and printed materials, any upgrades and this EULA); (iii) if you do not retain any copies of any portion of the Software; (iv) if the recipient agrees to the terms of this EULA; and (v) if the Software is an upgrade, such transfer must also include all prior versions of the Software. You agree that failure to meet all of these conditions renders such transfer null and void.

d. Termination. Without prejudice to any other rights, Tyco may terminate this EULA if you fail to comply with the terms and conditions herein. In such event, you must immediately destroy all copies of the Software and all of its component parts. To the extent the Software is embedded in hardware or firmware, you will provide prompt access to Tyco or its representative to remove or lock Software features or functionality as Tyco determines.

e. Subsequent EULA. Tyco may also supersede this EULA with a subsequent EULA pursuant to providing you with any future component, release, upgrade or other modification or addition to the Software. Similarly, to the extent that the terms of this EULA conflict with any prior EULA or other agreement between you and Tyco regarding the Software, the terms of this EULA shall prevail.

f. Incorporation of "Open Source" and other Third Party Software. Portions of the Software may be subject to certain third party license agreements governing the use, copying, modification, redistribution and warranty of those portions of the Software, including what is commonly known as "open source" software. Such portions of the Software are governed solely by the terms of such other license, and no warranty is provided under this License for open source software. By using the Software you are also agreeing to be bound to the terms of such third party licenses. If provided for in the applicable third party license, you may have a right to reverse engineer such software or receive source code for such software for use and distribution in any program that you create, so long as you in turn agree to be bound to the terms of the applicable third party license, and your programs are distributed under the terms of that license. If applicable, a copy of such source code may be obtained free of charge by contacting your Tyco representative.

g. Trademarks. This EULA does not grant you any rights in connection with any trademarks or service marks of Tyco, its affiliates or its suppliers.

h. Rental. You may not sublicense, rent, lease or lend the Software. You may not make it available to others or post it on a server or web site or otherwise distribute it.

i. **Software Keys.** The hardware/software key, where applicable, is your proof of license to exercise the rights granted herein and must be retained by you. Lost or stolen keys will not be replaced.

j. **Demonstration and Evaluation Copies.** A demonstration or evaluation copy of the Software is covered by this EULA; provided that the licenses contained herein shall expire at the end of the demonstration or evaluation period.

k. **Registration of Software.** The Software may require registration with Tyco prior to use. If you do not register the Software, this EULA is automatically terminated and you may not use the Software.

l. **Additional Restrictions.** The Software may be subject to additional restrictions and conditions on use as specified in the documentation accompanying such Software, which additional restrictions and conditions are hereby incorporated into and made a part of this EULA.

m. **Upgrades and Updates.** To the extent Tyco makes them available, Software upgrades and updates may only be used to replace all or part of the original Software that you are licensed to use. Software upgrades and updates do not increase the number of copies licensed to you. If the Software is an upgrade of a component of a package of Software programs that you licensed as a single product, the Software may be used and transferred only as part of that single product package and may not be separated for use on more than one computer or System. Software upgrades and updates downloaded free of charge via a Tyco authorized World Wide Web or FTP site may be used to upgrade multiple Systems provided that you are licensed to use the original Software on those Systems.

n. **Tools and Utilities.** Software distributed via a Tyco-authorized World Wide Web or FTP site (or similar Tyco-authorized distribution means) as a tool or utility may be copied and installed without limitation provided that the Software is not distributed or sold and the Software is only used for the intended purpose of the tool or utility and in conjunction with Tyco products. All other terms and conditions of this EULA continue to apply.

o. **Compliance with Law.** Certain functions of the Software may require compliance by you with local, national and international laws and regulations. You are solely responsible for compliance with all applicable laws and regulations relating to your use of those functions, including but not limited to those laws and regulations pertaining to personal data protection, privacy and security, any laws relating to the collection and sharing of personal data, including video and face recognition with third parties, or any laws requiring notice to or consent of persons with respect to your use of the capabilities and functionalities of the Software.

4. **EXPORT RESTRICTIONS.** You agree that you will not export, re-export or transfer any portion of the Software, or any direct product thereof (the foregoing collectively referred to as the "Restricted Components"), to IRAN, NORTH KOREA, SYRIA, CUBA and SUDAN, including any entities or persons in those countries, either directly or indirectly ("Tyco's Position"). You also agree that you will not export, re-export or transfer the Restricted Components to any other countries except in full compliance with all applicable governmental requirements, including but not limited to applicable economic sanctions and constraints administered by the U.S. Treasury Department and applicable export control measures administered by the U.S. Department of Commerce and U.S. Department of State, any other U.S. government agencies, and measures administered by the European Union or the government agencies of any other countries. Any violation by you of the applicable laws or regulations of the U.S. or any other government, or where you breach Tyco's Position notwithstanding whether or not this is contrary to any aforementioned applicable laws or regulations, will result in automatic termination of this EULA.

5. **U.S. GOVERNMENT RESTRICTED RIGHTS.** The Software is Commercial Computer Software provided with "restricted rights" under Federal Acquisition Regulations and agency supplements to them. Any use, duplication or disclosure by the U.S. Government is subject to restrictions as set forth in subparagraph (c)(1)(ii) of the Rights in Technical Data and Computer Software clause at DFAR 255.227-7013 et. seq. or 252.211-7015, or subparagraphs (a) through (d) of the Commercial

Computer Software Restricted Rights at FAR 52.227-19, as applicable, or similar clauses in the NASA FAR Supplement. Contractor/manufacturer is Sensomatic Electronics, LLC, 6 Technology Park Drive, Westford, MA 01886.

6. LIMITED WARRANTY.

a. **Warranty.** Tyco warrants that the recording medium on which the Software is recorded, hardware key, and the documentation provided with it, will be free of defects in materials and workmanship under normal use for a period of ninety (90) days from the date of delivery to the first user. Tyco further warrants that for the same period, the Software provided on the recording medium under this license will substantially perform as described in the user documentation provided with the product when used with specified hardware. THE FOREGOING EXPRESS WARRANTY REPLACES AND IS IN LIEU OF ALL OTHER WARRANTIES OR CONDITIONS, WHETHER EXPRESS, IMPLIED, OR STATUTORY, INCLUDING BUT NOT LIMITED TO, ANY IMPLIED OR OTHER WARRANTIES OF MERCHANTABILITY, FITNESS FOR A PARTICULAR PURPOSE, TITLE, NON-INFRINGEMENT OR NON-MISAPPROPRIATION OF INTELLECTUAL PROPERTY RIGHTS OF A THIRD PARTY, CUSTOM, TRADE, QUIET ENJOYMENT, ACCURACY OF INFORMATIONAL CONTENT, OR SYSTEM INTEGRATION. TYCO MAKES NO WARRANTY THAT ANY PORTION OF THE SOFTWARE WILL OPERATE ERROR-FREE, FREE OF ANY SECURITY DEFECTS OR IN AN UNINTERRUPTED MANNER. TYCO SHALL NOT BE RESPONSIBLE FOR PROBLEMS CAUSED BY CHANGES IN THE OPERATING CHARACTERISTICS OF THE DEVICE(S) UPON WHICH THE SOFTWARE IS OPERATING, OR FOR PROBLEMS IN THE INTERACTION OF THE SOFTWARE WITH NON-TYCO SOFTWARE OR HARDWARE PRODUCTS. TYCO NEITHER ASSUMES NOR AUTHORIZES ANY OTHER PERSON PURPORTING TO ACT ON ITS BEHALF TO MODIFY OR TO CHANGE THIS WARRANTY, NOR TO ASSUME FOR IT ANY OTHER WARRANTY OR LIABILITY CONCERNING THIS SOFTWARE. THE WARRANTY MADE BY TYCO MAY BE VOIDED BY ABUSE OR MISUSE. THIS LIMITED WARRANTY GIVES YOU SPECIFIC LEGAL RIGHTS. YOU MAY HAVE OTHER RIGHTS UNDER MANDATORY LAW THAT VARY FROM STATE TO STATE AND COUNTRY TO COUNTRY.

b. **Exclusive Remedy.** Tyco's entire liability and your exclusive remedy under the warranty set forth in this Section 6 will be, at Tyco's option, to (i) attempt to correct Software errors with efforts Tyco believes suitable to the problem, (ii) replace at no cost the recording medium, Software or documentation with functional equivalents as applicable, or (iii) refund a pro-rated portion of the license fee paid for such Software (less depreciation based on a five-year life expectancy) and terminate this EULA, provided, in each case, that Tyco is notified in writing of all warranty problems during the applicable warranty period. Any replacement item will be warranted for the remainder of the original warranty period. No remedy is provided for failure of the Software if such failure is the result of accident, abuse, alteration or misapplication with respect to the Software or any hardware on which it is loaded. Warranty service or assistance is provided at the original point of purchase.

7. LIMITATION OF LIABILITY & EXCLUSION OF DAMAGES.

a. **LIMITATION OF LIABILITY.** IN NO EVENT WILL TYCO'S AGGREGATE LIABILITY (INCLUDING, BUT NOT LIMITED TO, LIABILITY FOR NEGLIGENCE, STRICT LIABILITY, BREACH OF CONTRACT, MISREPRESENTATION AND OTHER CONTRACT OR TORT CLAIMS) ARISING FROM OR RELATED TO THIS EULA, OR THE USE OF THE SOFTWARE, EXCEED THE GREATER OF USD\$5.00 OR THE AMOUNT OF FEES YOU PAID TO TYCO OR ITS RESELLER FOR THE SOFTWARE THAT GIVES RISE TO SUCH LIABILITY. BECAUSE AND TO THE EXTENT THAT SOME JURISDICTIONS DO NOT ALLOW THE EXCLUSIONS OR LIMITATIONS OF LIABILITY ABOVE, THESE MAY NOT APPLY TO YOU. b. **EXCLUSION OF OTHER DAMAGES.** UNDER NO CIRCUMSTANCES SHALL TYCO OR ANY OF ITS RESELLERS OR LICENSORS BE LIABLE FOR ANY OF THE FOLLOWING: (I) THIRD PARTY CLAIMS; (II) LOSS OR DAMAGE TO ANY SYSTEMS, RECORDS OR DATA, OR LIABILITIES RELATED TO A VIOLATION OF AN INDIVIDUAL'S PRIVACY RIGHTS; OR (III) INDIRECT,

INCIDENTAL, SPECIAL, CONSEQUENTIAL, PUNITIVE, RELIANCE, OR COVER DAMAGES (INCLUDING LOST PROFITS AND LOST SAVINGS), IN EACH CASE EVEN IF TYCO HAS BEEN ADVISED OF THE POSSIBILITY OF SUCH DAMAGES. YOU ARE SOLELY RESPONSIBLE AND LIABLE FOR VERIFYING THE SECURITY, ACCURACY AND ADEQUACY OF ANY OUTPUT FROM THE SOFTWARE, AND FOR ANY RELIANCE THEREON. SOME JURISDICTIONS DO NOT ALLOW THE EXCLUSION OF INCIDENTAL OR CONSEQUENTIAL DAMAGES, OR THE LIMITATION ON HOW LONG AN IMPLIED WARRANTY LASTS, SO SOME OF THE ABOVE LIMITATIONS MAY APPLY TO YOU ONLY TO THE EXTENT PERMITTED BY THOSE LAWS.

8. GENERAL. If any provision of this EULA is found to be unlawful, void, or for any reason unenforceable, then that provision shall be severed from this EULA and shall not affect the validity and enforceability of the remaining provisions. You should retain proof of the license fee paid, including model number, serial number and date of payment, and present such proof of payment when seeking service or assistance covered by the warranty set forth in this EULA. This EULA is governed by the laws of the State of New York, without regards to its conflicts of law principles. The parties hereby irrevocably agree that they submit themselves to the personal jurisdiction of the state and federal courts of New York for purposes of resolving any and all disputes arising under or related to these terms and conditions. The parties specifically exclude the application of the provisions of the United Nations Convention on Contracts for the International Sale of Goods.

9. ADDITIONAL NOTICES.

a. For Software that implements the MPEG-4 Visual Standard: PORTIONS OF THIS PRODUCT ARE LICENSED UNDER THE MPEG-4 VISUAL PATENT PORTFOLIO LICENSE FOR THE PERSONAL AND NON-COMMERCIAL USE OF A CONSUMER FOR (I) ENCODING VIDEO IN COMPLIANCE WITH THE MPEG-4 VISUAL STANDARD ("MPEG-4 VIDEO") AND/OR (II) DECODING MPEG-4 VIDEO THAT WAS ENCODED BY A CONSUMER ENGAGED IN A PERSONAL AND NON-COMMERCIAL ACTIVITY AND/OR WAS OBTAINED FROM A VIDEO PROVIDER LICENSED BY MPEG LA TO PROVIDE MPEG-4 VIDEO. NO LICENSE IS GRANTED OR SHALL BE IMPLIED FOR ANY OTHER USE. ADDITIONAL INFORMATION INCLUDING THAT RELATING TO PROMOTIONAL, INTERNAL AND COMMERCIAL USES AND LICENSING MAY BE OBTAINED FROM MPEG LA, LLA. SEE [HTTP://WWW.MPEGLA.COM](http://www.mpegla.com).

b. For Software that implements the AVC Standard: PORTIONS OF THIS PRODUCT ARE LICENSED UNDER THE AVC PATENT PORTFOLIO LICENSE FOR THE PERSONAL USE OF A CONSUMER OR OTHER USES IN WHICH IT DOES NOT RECEIVE REMUNERATION TO (i) ENCODE VIDEO IN COMPLIANCE WITH THE AVC STANDARD ("AVC VIDEO") AND/OR (ii) DECODE AVC VIDEO THAT WAS ENCODED BY A CONSUMER ENGAGED IN A PERSONAL ACTIVITY AND/OR WAS OBTAINED FROM A VIDEO PROVIDER LICENSED TO PROVIDE AVC VIDEO. NO LICENSE IS GRANTED OR SHALL BE IMPLIED FOR ANY OTHER USE. ADDITIONAL INFORMATION MAY BE OBTAINED FROM MPEG LA, L.L.C. SEE [HTTP://WWW.MPEGLA.COM](http://www.mpegla.com)