

Quick Start Guide

(8200-1953-08_A0)

Tyco Illustra Pro 5MP Thermal Elevated Skin Temperature Detection Camera

(Product Code: IPT05-B29-BIA3)

In the box

- 1 x Camera
- 4 x PA 4x25mm screws
- 4 x 6x29mm plastic screw anchors
- 1 x machine screw
- 4 x 4x10mm screws
- 1 x L-key hexagonal wrench
- 1 x Mounting template
- 1 x Camera adaptor plate
- 1 x Blackbody device
- 1 x Quick Start Guide
- 2 x Ferrite clamps

Installation tools

- Screwdriver
- L-key hexagonal wrench



Table 1: Camera part descriptions

Number	Camera part description
1	Camera lens
2	Sun shield cover
3	Sun shield cover adjustment thumb-screw
4	Camera base
5	Pan Adjustment connection
6	Tilt Adjustment connection
7	Camera body (Buttons and SD card slot are located on the underside of the camera). Note: You will need to remove the cover to access them.

Figure 2: Cable connections

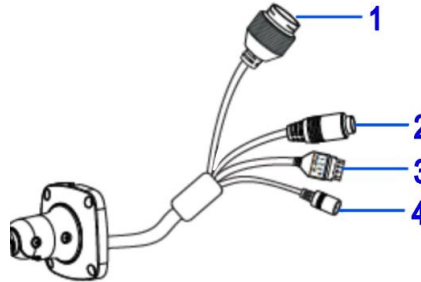

Figure 2

Figure 3: Camera buttons and SD card slot (continued)

Note: Remove the two screws on the camera cover (1) (Figure 3) to access the buttons. **Securely attach the cover when finished.**

Table 3: Camera button descriptions and SD card slot

Number	Camera button description
1	Camera button cover
2	Micro SD Card Slot
3	Reset button (Hold for more than 3 seconds)

Quick reference

- Default IP: 192.168.1.168 (DHCP enabled)
- Default Username / Password: admin / admin
- Power: 12VDC, 2A - For 12VDC power supply, use Pihong AC adaptor, model PMA36R-120 (not provided) **or** PoE 48VDC, 0.35A - For PoE power, use AXIS Communications, AXIS T8134 MIDSPAN 60W, model 5900-331-01 (not provided).
- Use Internet Explorer 11 web browser

Mounting the camera to a wall or ceiling

1. Place the mounting template on the surface that you want to attach the camera.
2. On the surface drill four Ø 5mm holes and cut out a >30 Ømm cable hole as per the markings identified on the mounting template.
3. Securely place the four screw anchors into the four holes.
4. Place the camera cable through the cable hole on the mounting surface.
5. Hold the camera base (4) (Figure 1) up to the mounting template and align the four holes on the camera base with the four holes on the mounting surface.

Mounting the camera to a wall or ceiling (continued)

6. Insert the four PA 4x25mm screws into the four holes on the camera base and securely attach the camera to the mounting surface.
7. Attach the ferrite 'round clamp' to the large single camera cable.
Note: Ensure that the ferrite clamp (1) (Figure 4) is positioned close to the camera base on the cable.

Figure 4: Round ferrite clamp position on the cable

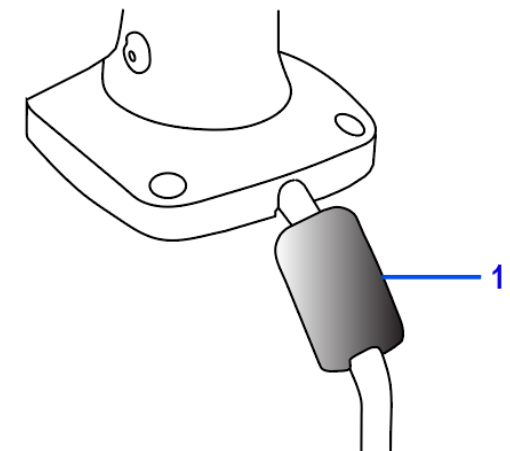

Figure 4

Figure 1: Camera parts

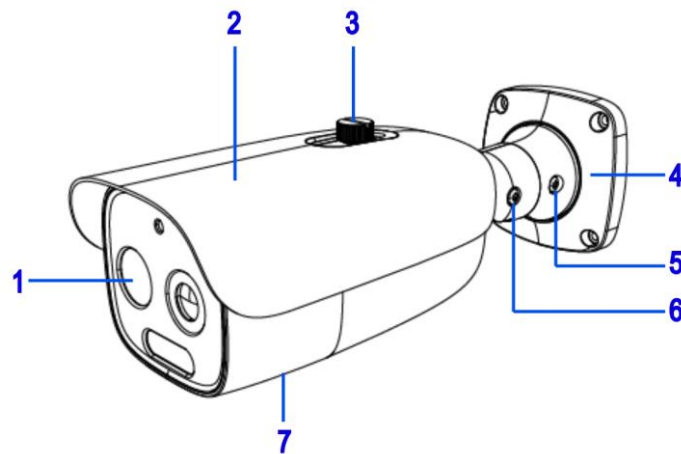

Figure 1

Table 2: Cable connection descriptions

Number	Cable connection description
1	Ethernet Connector and also supports PoE
2	Audio Input (Max 30V DC / 30mA)
3	Alarm Output / Input (5V DC @10mA)
4	Power Connector (12V DC @ 1A)

Figure 3: Camera buttons and SD card slot

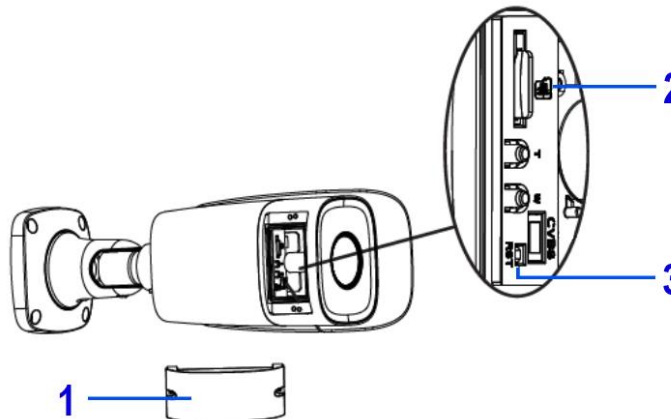

Figure 3

Mounting the camera to a wall or ceiling (continued)

Note: The camera must be connected to earth ground.

8. Attach a ring-type terminal to the end of the ground wire (2) (Figure 5) (not provided). Insert the machine screw through the ring terminal and attach to the camera (1) (Figure 5).

Figure 5: Earth wire connection

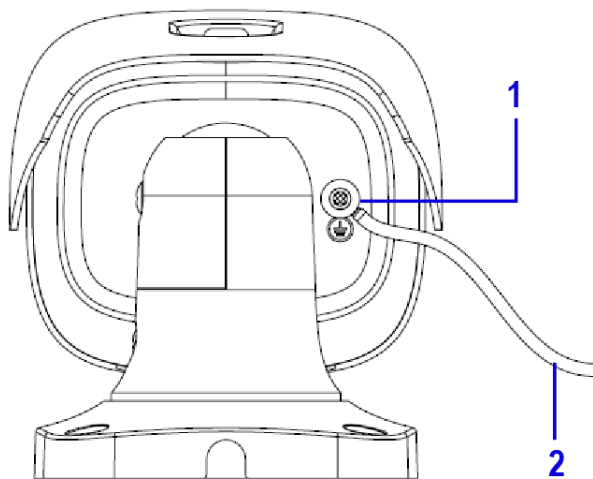

Figure 5

Adjusting the camera position

1. Use the L-key hexagonal wrench to:
 - i. Unlock the screw (1) (Figure 7) and pan the camera field of view up to 360 degrees.
 - ii. Unlock the screw (2) (Figure 7) to tilt the camera body up to 90 degrees.
 - iii. Unlock the screw (3) (Figure 7) and rotate the camera body up to 360 degrees.

Note: You must securely lock each screw to ensure that the camera holds the modified position.

Figure 7: Pan, tilt and rotate screws

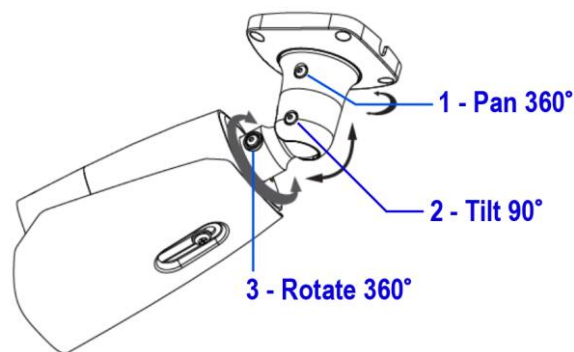

Figure 7

Mounting the camera to a tripod stand (continued)

- Connect a shielded PoE cable to the ethernet / PoE slot on the camera cable. **Note:** You **must** first attach the ferrite 'rectangle clamp' around the Ethernet cable (1) (Figure 2). The cable (1) (Figure 6) **must** loop around the clamp (2) (Figure 6) before the clamp is enclosed.

Figure 8: Single face usage setup distance recommendations

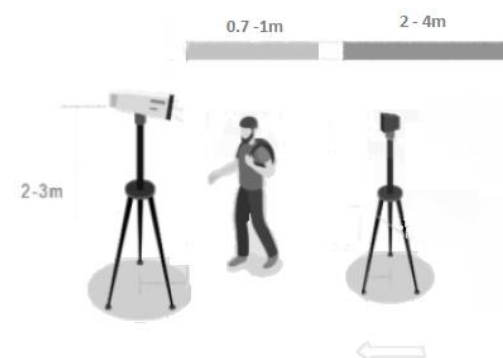

Figure 8

Mounting the camera to a wall or ceiling (continued)

9. To power up the camera:

- Connect a 12V DC power supply to the power connector on the camera cable.

OR

- Connect a shielded PoE cable to the ethernet / PoE slot on the camera cable. **Note:** You **must** first attach the ferrite 'rectangle clamp' around the Ethernet cable (1) (Figure 2). The cable (1) (Figure 6) **must** loop around the clamp (2) (Figure 6) before the clamp is enclosed.

Figure 6: Cable looped inside the ferrite clamp

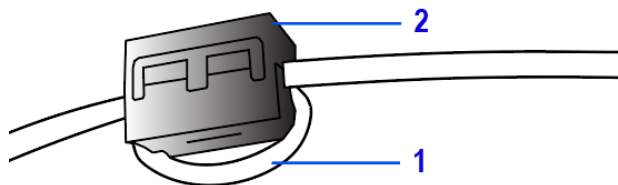

Figure 6

Adjusting the sun shield

1. Loosen the thumb-screw (3) (Figure 1) to move the sun shield cover forward and backward over the camera body (7) (Figure 1). **Note:** You must securely lock the thumb screw to ensure that the sun shield cover holds the modified position.

Mounting the camera to a tripod stand

1. Install the tripod as per the instructions that come with it.
2. Align the four holes on the camera adaptor plate with the four holes on the camera base and insert the four 4x10mm screws into the four holes and securely attach the camera adaptor plate to the camera base. **Note:** The camera is now attached to the camera adaptor plate.
3. Place the camera adaptor plate on top of the tripod stand and align the 1/4 " threaded screw connection underneath the camera adaptor plate with the threaded screw on the tripod stand.
4. Rotate the camera adaptor plate to securely attach it to the tripod stand.
5. Insert all camera cables through the cable side entry notch on the camera base.
6. Attach the ferrite 'round clamp' to the large single camera cable. **Note:** Ensure that the ferrite clamp (1) (Figure 4) is positioned close to the camera base on the cable. **Note:** The camera must be connected to earth ground.
7. Attach a ring-type terminal to the end of the ground wire (2) (Figure 5) (not provided). Insert the machine screw through the ring terminal and attach to the camera (1) (Figure 6).
8. To power up the camera:

- Connect a 12V DC power supply to the power connector on the camera cable.

OR

(See the bullet point in the next section to continue on)

Figure 9: Multi face usage setup distance recommendations

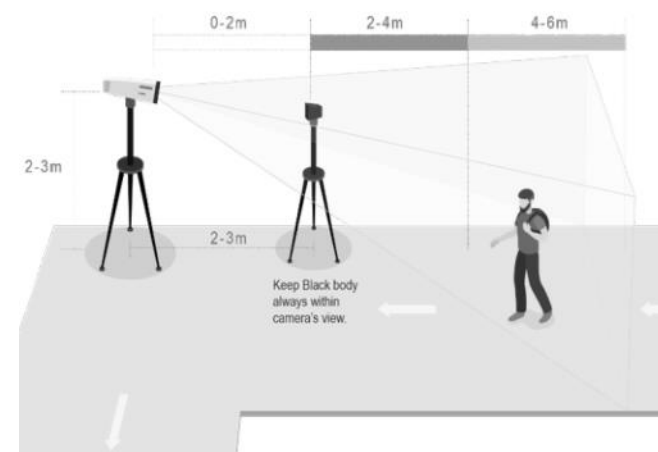

Figure 9

Calibration / accuracy

- This device is specified to achieve a +/- 0.5°C accuracy when configured properly following the installation guide and calibrated against a Blackbody device. Calibration must be done following device calibration intervals in line with the user manual guidance in order to maintain the specified accuracy.
- The blackbody device is used to manage thermal drift compensation and is crucial in obtaining accurate temperature assessments in line with the product accuracy specifications.

Calibration / accuracy (continued)

- The solution uses the forehead region of the face using 4 sampling spots of 3x3 pixels as the workable target plane. The total of 36 pixels is then verified to be within 0.2°C averaged across all the pixels to ensure consistency with the highest observed temperature being reported with the camera conducting automated calibration with the blackbody device to manage thermal drift compensation.

Guidelines

- **System architects, installers, users, and operators should refer to guidelines in ISO/TR 13154: Medical electrical equipment — Deployment, implementation and operational guidelines for identifying febrile humans using a screening thermograph.**
- **Temperature measurement with this device should not be solely or primarily relied upon to diagnose or exclude a diagnosis of any illness, disease or other medical condition.**
- **The device is tested and labelled consistent with the standard IEC 80601-2-59:2017: Medical electrical equipment – Part 2-59: Particular requirements for the basic safety and essential performance of screening thermographs for human febrile temperature screening.**
- **Elevated skin temperature in the context of use should be confirmed with a secondary evaluation method such as a clinical grade contact thermometer.**
- **The system operator must ensure the face is unobstructed by hair, eyeglasses, and other objects because their presence will interfere with the ability of a screening thermograph to detect a febrile condition.**

Guidelines (continued)

- **The relative humidity in the screening area should be maintained below 50 % and the temperature below 24 °C for best performance. A screening area with elevated humidity and ambient temperature may lead to inaccurate temperature measurements due changes in skin temperature caused by sweating.**
- **Public health officials, through their experience with the device in the particular environment of use, should determine the significance of any fever or elevated temperature based on the skin tele thermographic temperature measurement.**
- **This device should be used to measure only one subject's temperature at time in accordance with IEC 80601-2-59:2017 and FDA (or other applicable regulatory) guidelines for accuracy.**
- **The visible thermal patterns of this device are only intended for locating the points from which to extract the thermal measurement.**
- **The product calibration interval is 14 days.**

Factors to consider for the environment and installation that can impact measurement

- Thermal camera is temperature-sensitive. When it is used for temperature measuring, in order to ensure the accuracy, the recommended ambient temperature for operation is 0~35°C and the infrared light should be turned off during the temperature measurement.

Factors to consider for the environment and installation that can impact measurement (continued)

- Thermal camera should always be used together with blackbody both for increased accuracy and to comply with IEC standards for measurement thermographs for human febrile temperature measurement.
- Thermal camera should be used in a stable indoor environment without wind. Please make sure the monitoring field is far away from any objects that could produce airflow, high temperature, reflection.
- Don't install the thermal camera opposite to a door, air conditioner or any place in or near infrared sources such as sunlight.
- For monitoring, the best temperature measurement distance is 2~4m, recommended distance should be 2~6m to achieve specified accuracy.
- Set up a one-way temperature measuring zone and make sure the camera can clearly see the human face.
- After turning on, the thermal camera needs to wait 20~30 minutes to be steady.
- It is recommended to use DC 12V power supply to reduce power consumption.
- The blackbody used with the camera shall be installed 2 or 3 meters away from the camera and opposite to the camera. It cannot be blocked. During operation, do not move the camera and blackbody and make sure the blackbody is in a fixed and proper place in the camera image for calibration and thermal drift compensation.

Factors to consider for the environment and installation that can impact measurement (continued)

- The thermal camera and the blackbody device should be at a height of 2-3m and parallel to the faces being screened for temperature.
- If the camera and/or blackbody are relocated then the customer/user/installer needs to evaluate the new location and ensure it meets the criteria specified in this user manual, such as guidelines, factors to consider, warnings, configuration and calibration steps, environmental, power, air flow, and lighting parameters.
- For monitoring, the best temperature measurement distance is: Single Face Usage recommended distance should be 0.7~1m to achieve specified accuracy, with subject requiring to pause for about 1 second to allow for reading. Multi Face Usage recommended distance should be 2~6m to achieve specified accuracy.

Warnings

- If the product does not work properly, please contact your dealer or the nearest service centre. Never attempt to disassemble the camera yourself.
- Do not allow water or liquid intrusion into the camera.
- Installation and service should be performed only by qualified and experienced technicians and comply with all local codes and rules to maintain your warranty.
- When the product is mounted on a wall ensure that the device is firmly fixed.
- Do not use the camera beyond the specified voltage range.

Warnings (continued)

- Do not drop the camera or subject it to physical shock.
- Avoid touching the camera lens.
- If cleaning is necessary, please use a clean dry cloth and wipe the camera gently.
- If the device will not be used for a long time then cover the lens cap to protect it from dirt.
- Do not aim the camera at the sun or extra bright light sources.
- Do not place the camera in extremely hot, cold (the operating temperature shall be -0°C~35°C), dusty or damp locations, and do not expose it to high electromagnetic radiation.
- To avoid heat accumulation, good ventilation is required within the operating environment.
- Thermal imaging can detect individuals with elevated skin temperatures. However, it cannot detect or diagnose a fever or other medical conditions. The Illustra elevated skin temperature measurement solution does not cause and cannot eliminate or prevent occurrences of the events that it is intended to detect or avert.
- This product requires professional installation by a service technician with the appropriate training and experience necessary to ensure proper installation and configuration for the applicable operating environment and usage case to ensure the safe and accurate operation of the product.
- Product labeling is in line with the ISO/TR 13154 standard.

Warnings (continued)

- Faces should be unobstructed by hair, eyeglasses, and other objects because their presence will interfere with the ability of a thermograph detection to detect a febrile condition. The face should be in the center of the camera view and fill approximately 50% of the thermal sensor view to achieve a 240x180 pixel resolution of the face.
- A secondary screening with a clinical thermometer for any elevated skin temperature alert will required to confirm a febrile condition.
- Relative humidity in the area of screening should be maintained below 50% and the temperature below 24°C to achieve the documented accuracy. Sweating can impact the accuracy of temperature measurement.
- Infrared sources such as sunlight, nearby electrical sources and lighting, should be minimized to avoid impact on the accuracy of temperature reading.
- Airflow should be minimized in the area of the equipment to avoid impact on the accuracy of temperature detection.
- The target of the body surface temperature detection will be the forehead region of the face. 4 points of 9 pixels each. Three points factored on the center of the forehead region, then one point left and one point right with fourth point below the center point.